



**MONTERINGSANVISNING · INSTALLATION INSTRUCTIONS
MONTAGEANLEITUNG · INSTRUCTIONS DE MONTAGE**

Saab 9-3 M03-

Fog lights

Accessories Part No.	Group	Date	Instruction Part No.	Replaces
12 787 092	9:35-05	May 03	12 789 095	12 789 095 Oct 02

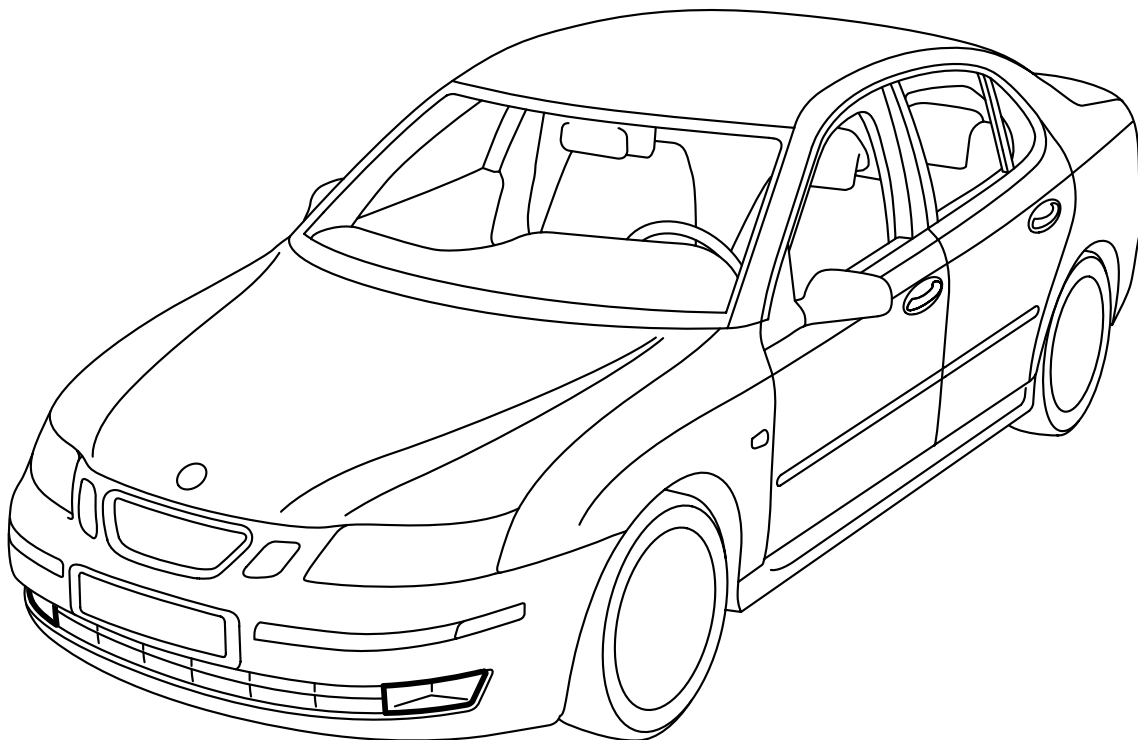

F980A110

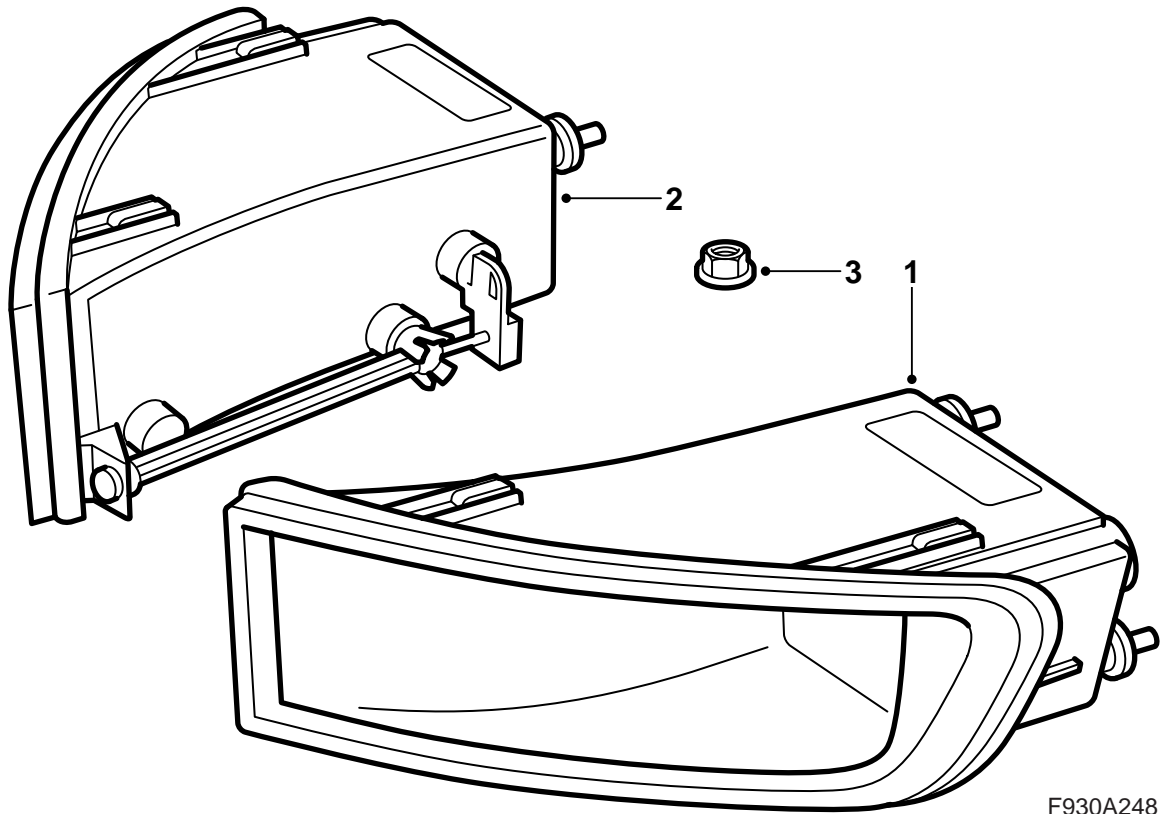

- 1 Fog light L
- 2 Fog light R
- 3 Nuts (x4)

The following part is also required (ordered separately)

Light Switch Position

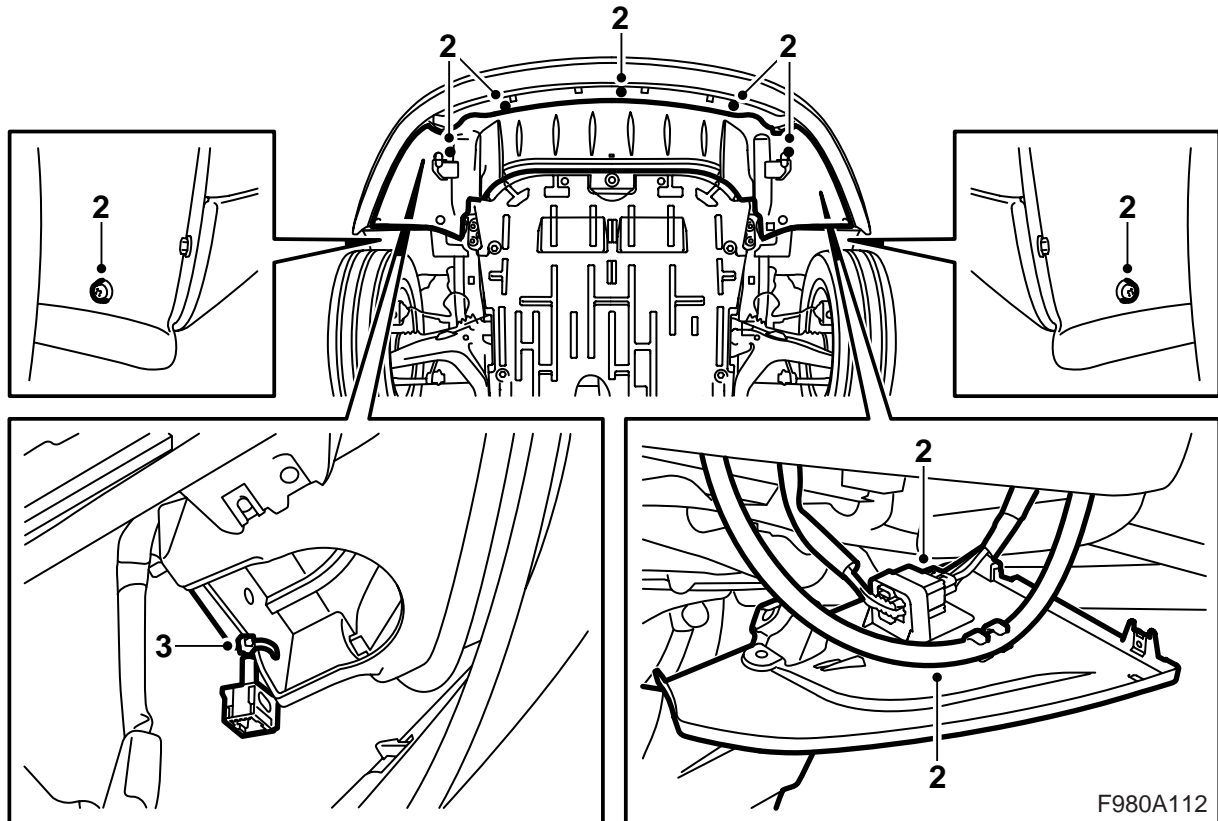

- 1 Raise the car.
- 2 Remove the spoiler shield, unplug the bumper connector and remove it from the holder on the spoiler shield.
Cars with headlamp washers: Unhook the hose from the spoiler shield.
- 3 Clip the cable ties securing the connectors.

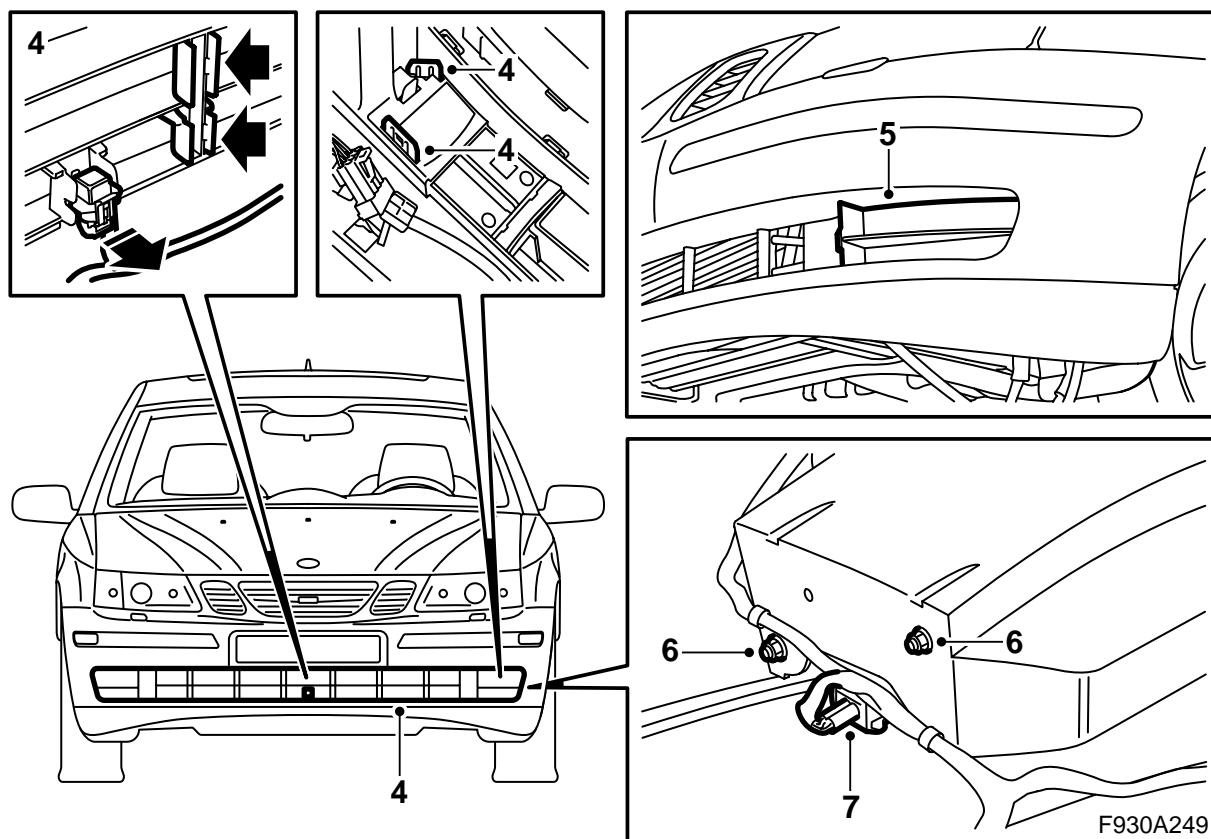

- 4 Remove the lower grille by bending in the locking tabs. Remove the temperature sensor from the grille.
- 5 Remove the covers.
- 6 Insert the fog light into the casing and fit the nuts.
- 7 Attach the connectors.

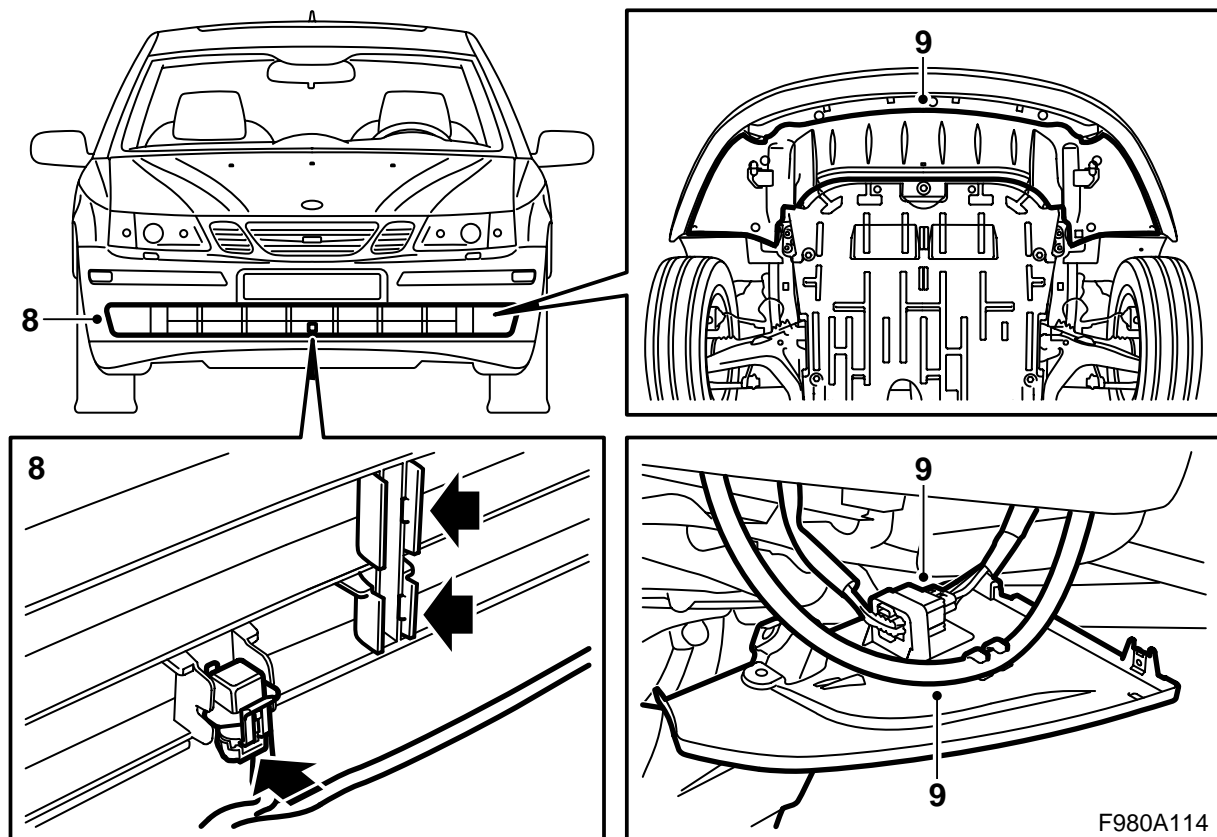

8 Fit the temperature sensor and the lower grille. Make sure the locking tabs fasten properly.

9 Lift up the spoiler shield, fit the bumper connector into the holder and plug in the connector.

Cars with headlamp washers: Hook the hose to the spoiler shield.

All: Fit the spoiler shield.

10 Lower the car.

11 Remove the cover on the electrical centre in the dashboard and remove the light switch by pressing from behind the panel. Unplug the connector.

12 Plug in the connector and fit the new light switch. Fit the cover on the dashboard electrical centre.

13 Connect the diagnostic tool, select car and model year, select "All", select "Add/Remove", select the accessory and then "Add".

Note

The diagnostic tool will on some occasions need to retrieve a security code in TIS. Information on what to do will be displayed on the diagnostic tool display.

14 Adjust the fog lights and check their function according to car specifications.

Example: In Europe, as per vehicle testing requirements, fog lights may be used if the parking lights, dipped or main beams have been switched on. In the USA, fog lights may be used in combination with the main beams.

Certain countries maintain divergent legal requirements, for instance in Sweden where it is not permitted to use fog lights in combination with dipped beams. Be acquainted with the current laws for the country in question.

15 **Cars with headlamp washers:** Check the function of the headlamp washers.