

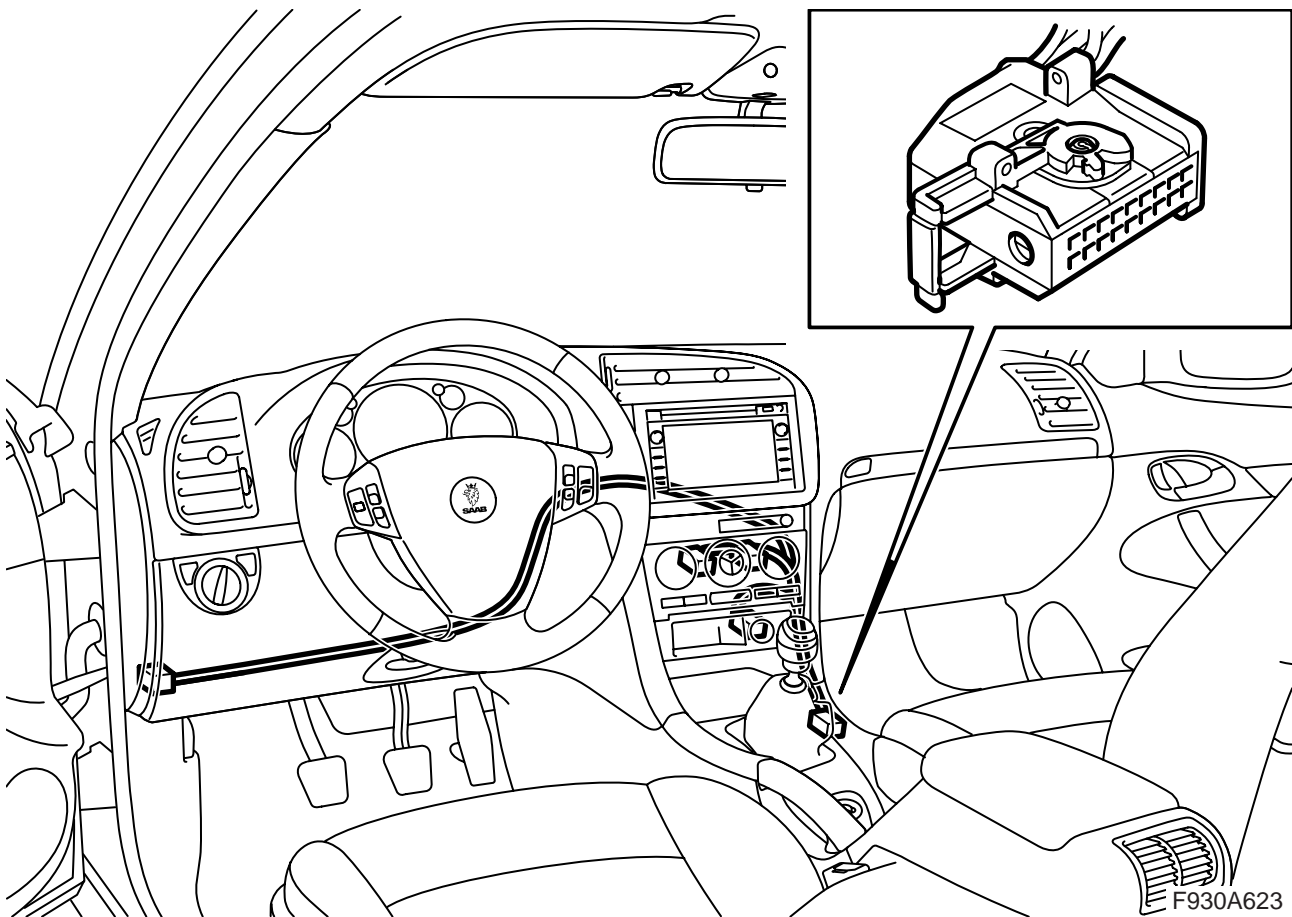

**MONTERINGSANVISNING · INSTALLATION INSTRUCTIONS
MONTAGEANLEITUNG · INSTRUCTIONS DE MONTAGE**

9-3 M03-06, radio/navigation page 3
9-3 M07-, radio. page 11
9-3 M07-, navigation page 18
9-5 M06-, radio/navigation page 26
Adapter harness, mobile phone

Accessories Part No.	Group	Date	Instruction Part No.	Replaces
32 025 900	9:89-32	Nov 06	32 025 908	



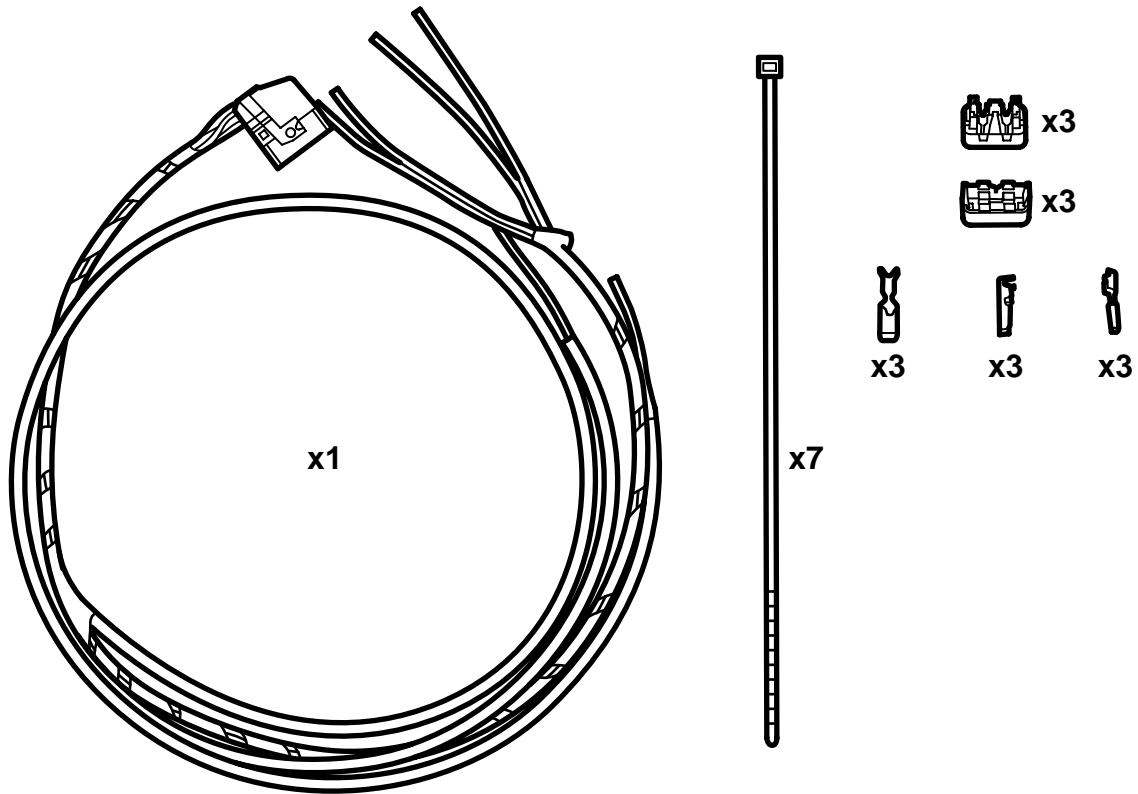

F930A540

9-3 M07 with navigation

The following are not included in the kit but are ordered separately:

- 12 769 716 Telephone line adaption unit
- 12 789 433 Connector housing
- 12 789 185 Locking
- 32 000 375 Cable terminals

9-3 M03-06, radio/navigation

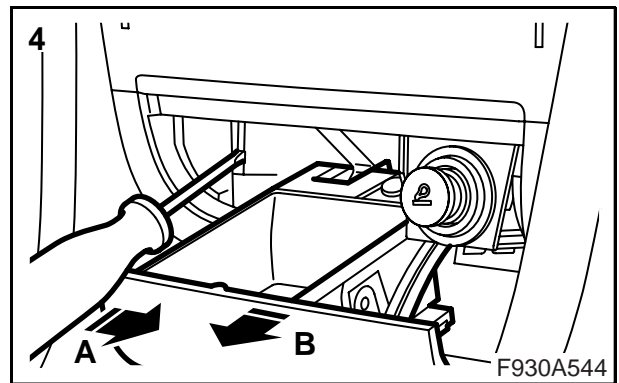
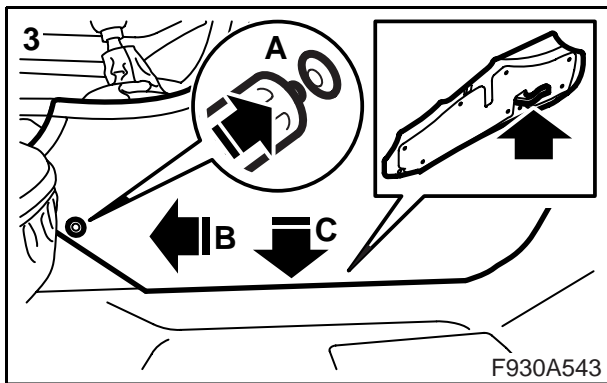
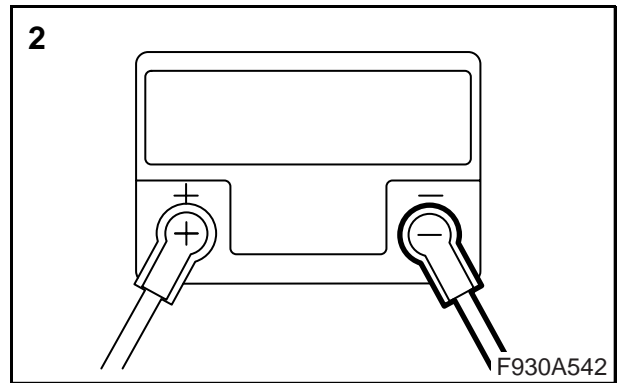
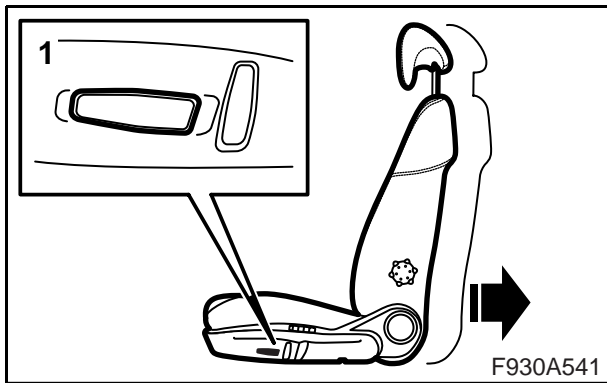

- 1 Move the passenger seat to its rearmost position.
- 2 Disconnect the battery negative cable (-).
- 3 Remove the floor console's front side protection.
- 4 Remove the ashtray/storage compartment.

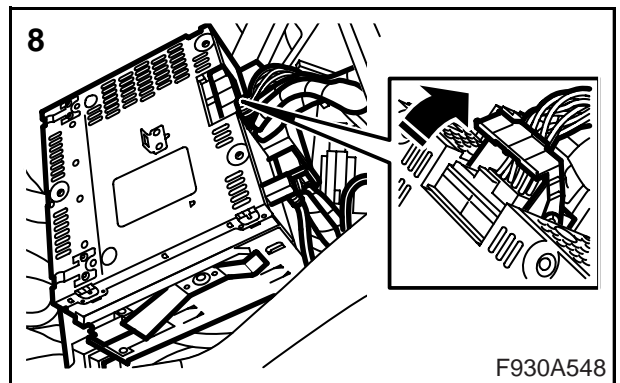
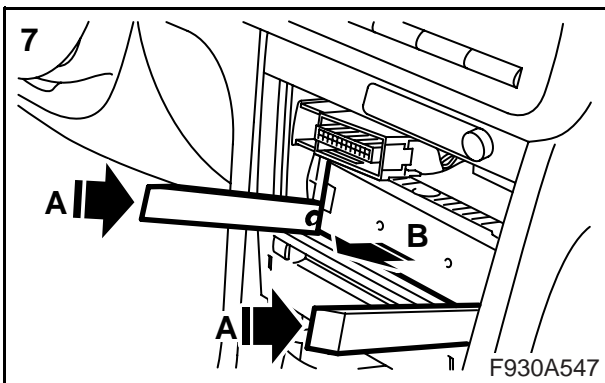
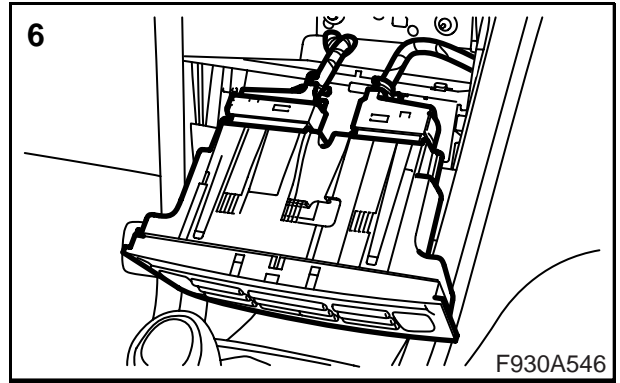
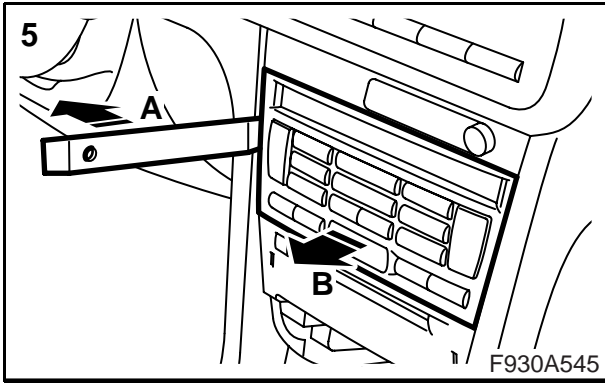

- 5 Remove the ACC/MCC unit.
- 6 Unplug the connectors.
- 7 Remove the head unit, press in the catches and take the unit out.
- 8 Unplug the head unit connectors.

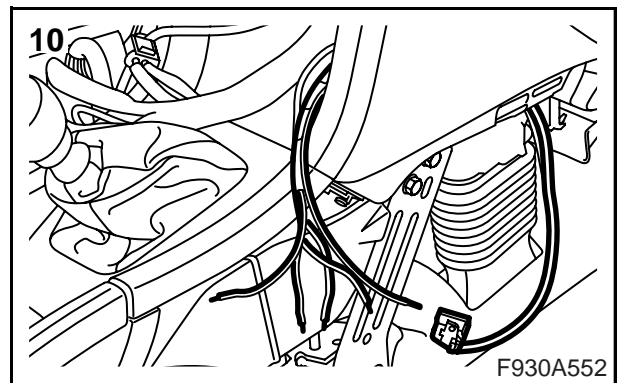
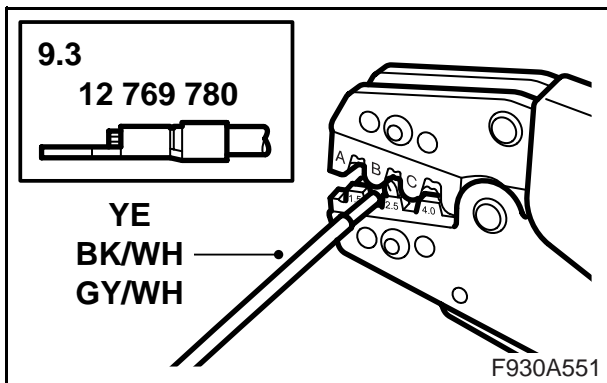
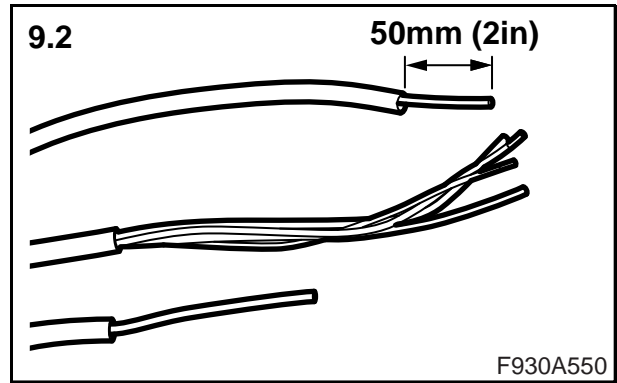
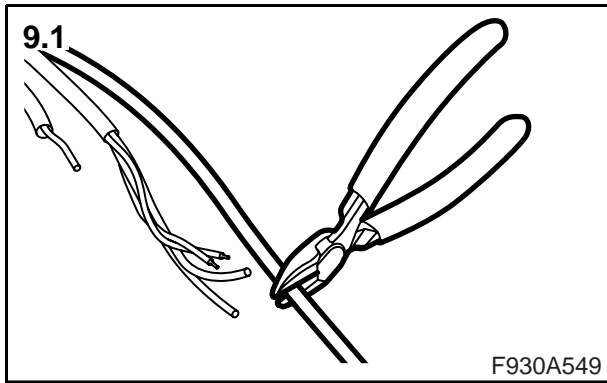

9 Prepared adapter harness (32 025 898):

- 9.1 Cut the yellow (YE) cable to the same length as the other cables in the adapter harness.
- 9.2 Cut the sheathing to approx. 50 mm and strip the cable end.
- 9.3 Crimp the cable terminals (12 769 780) to the black/white (BK/WH), grey/white (GY/WH) and yellow (YE) cable ends on the adapter harness.

Important

It is very important that the correct recess in the pliers is used. Check that the cable terminal is firmly secured.

10 Fit the adapter harness.

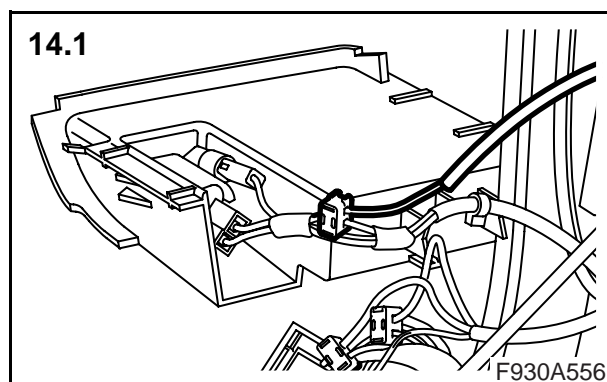
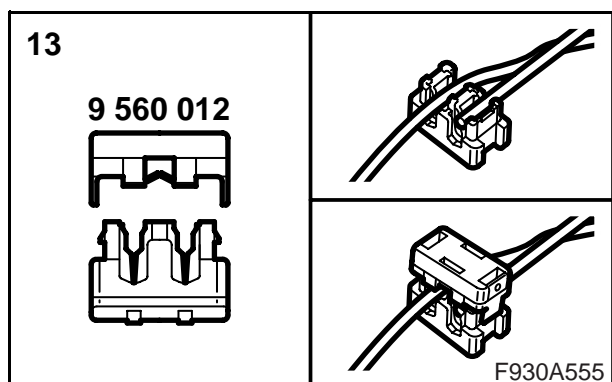
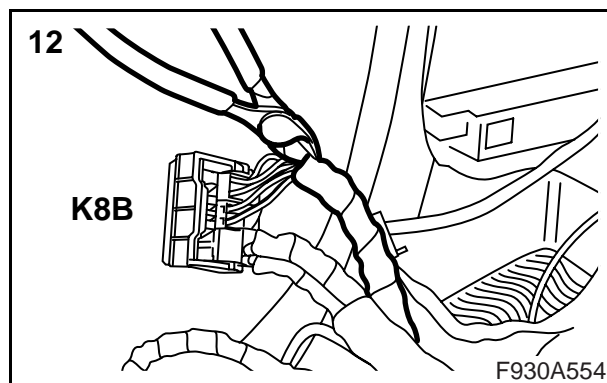
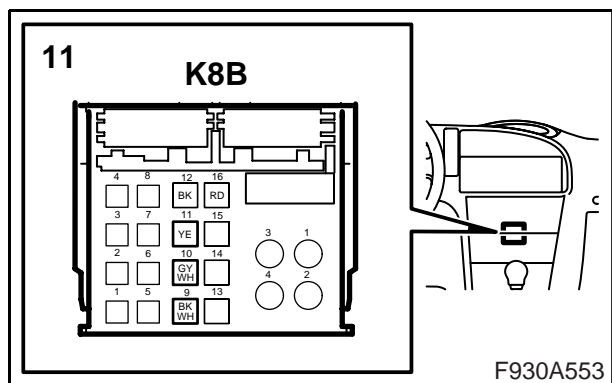

11 Connect the adapter harness to the car:

- BK/WH -> K8B pos 9 (line gnd)
- GY/WH -> K8B pos 10 (line out)
- YE -> K8B pos 11 (mute)

12 Klipp upp cirka 50 mm av tejpen till kontaktdonet K8B.

13 Splicing the wiring harness.

Important

In order to avoid damaging the wiring harness when splicing, the joining sleeve must only be clamped in once.

14 Connect the adapter harness to the car using joining sleeves:

- 14.1RD/BU -> 12 V socket BK (+15)

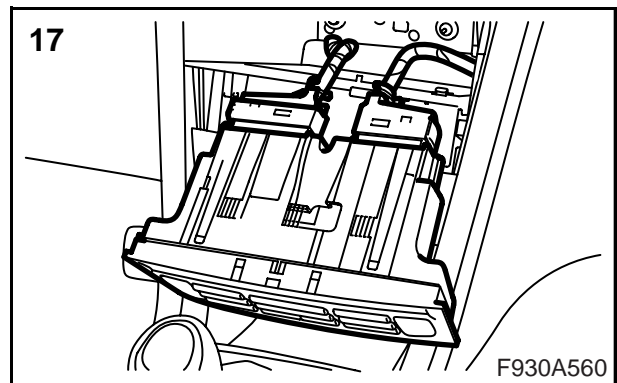
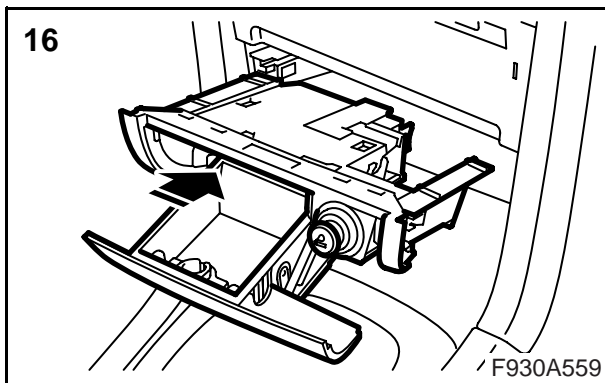
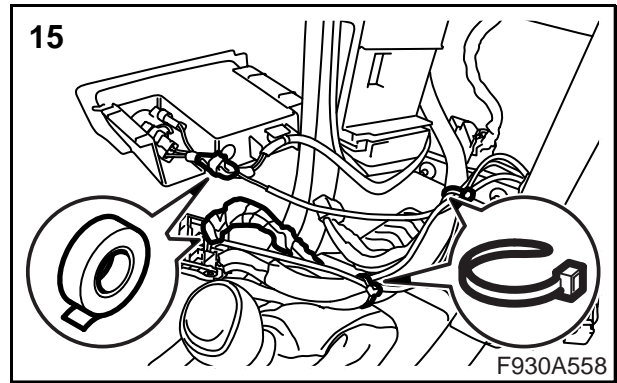
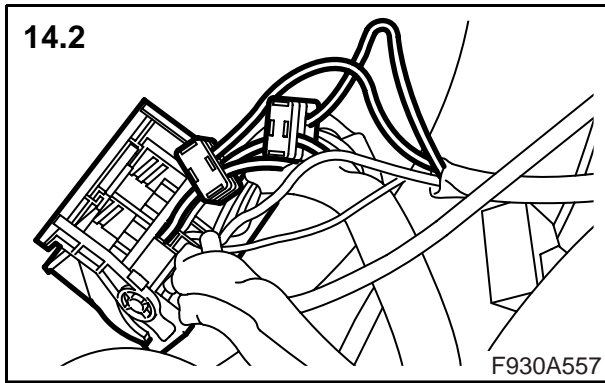

14.2BK -> K8B pos 12 (gnd)
RD -> K8B pos 16 (+30)

- 15 Protect the joints by insulating with fabric tape around the wiring harness. Secure the wiring harness.
- 16 Fit the ashtray/storage compartment.
- 17 Plug in the connectors.

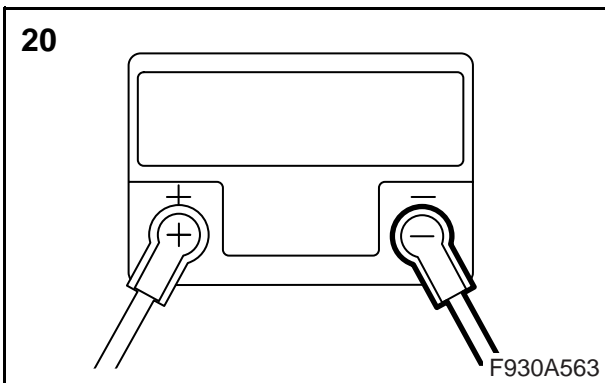
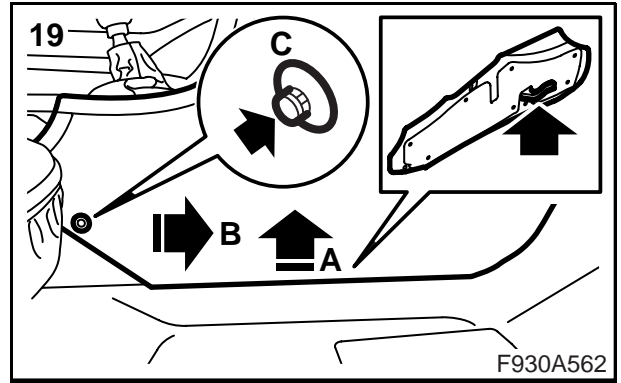
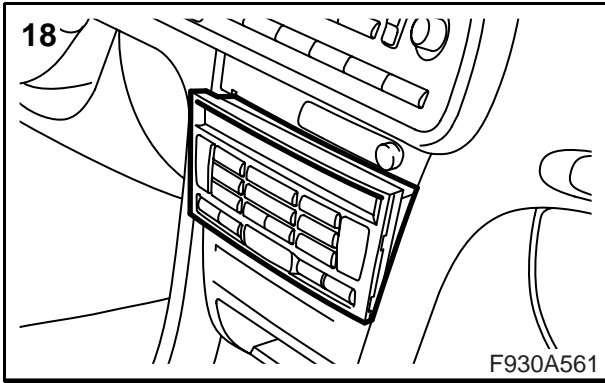

- 18 Fit the ACC/MCC unit.
- 19 Fit the floor console's front side protection.
- 20 Connect the battery negative cable (-).

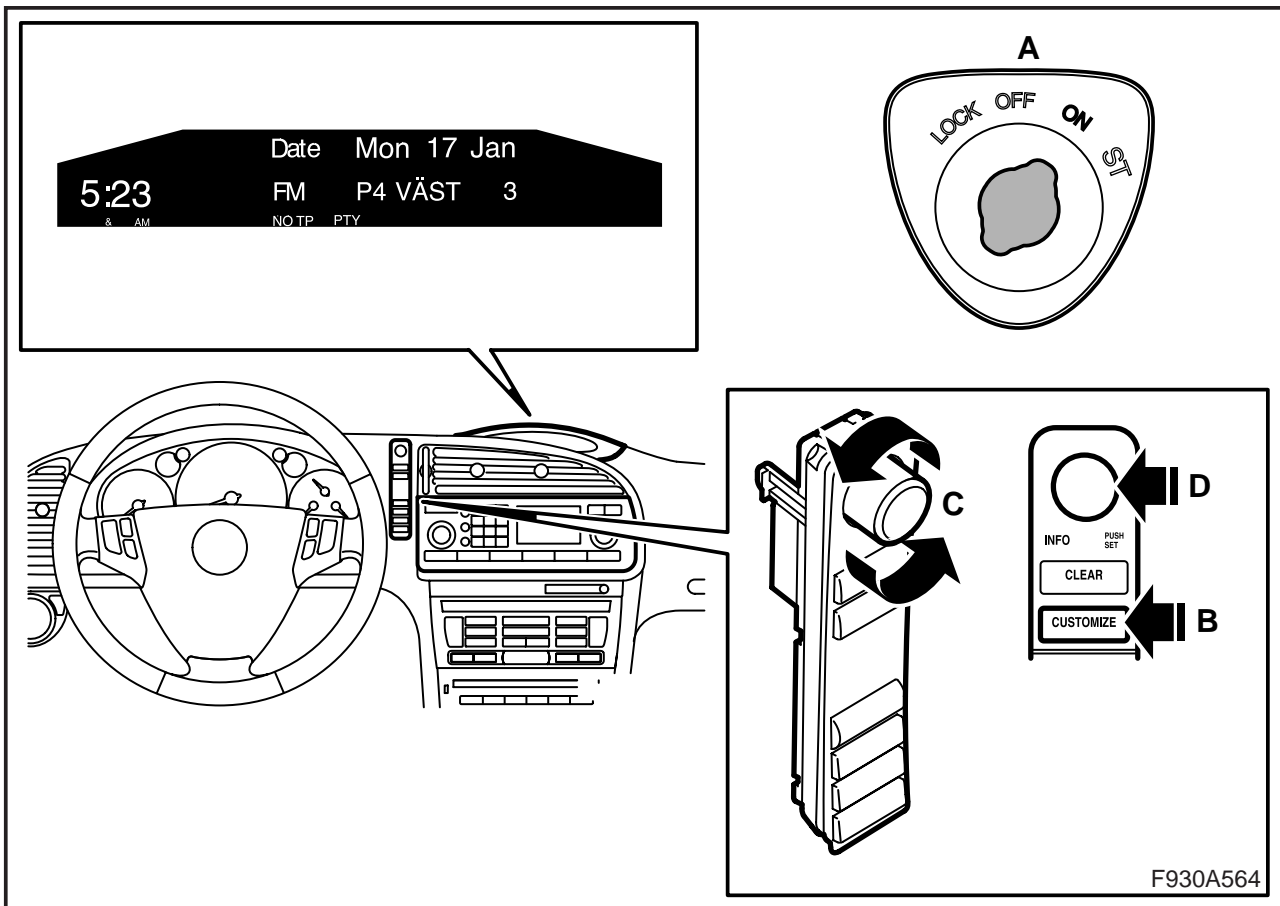

21 Set the date and time:

- 21.1 Turn the ignition key to the ON position (A).
- 21.2 Press the CUSTOMIZE button (B) in the SIDC (control panel, SID).
- 21.3 Turn the INFO button (C) until the display shows "Clock / Alarm". Press to confirm "OK".
- 21.4 Turn the INFO button (C) to "Set Clock". Press "OK".
- 21.5 Turn the INFO button (C) to "Manual" or "RDS adjust" and set the correct time. Press "OK".
- 21.6 Turn the INFO button (C) to "DATE".
- 21.7 Press in the INFO button (D) until the display shows "YEAR 2000".
- 21.8 Turn the INFO button (C) to the correct year. Press to confirm "OK".
- 21.9 Turn the INFO button (C) to the correct month. Press "OK".
- 21.10 Turn the INFO button (C) to the correct date. Press "OK".

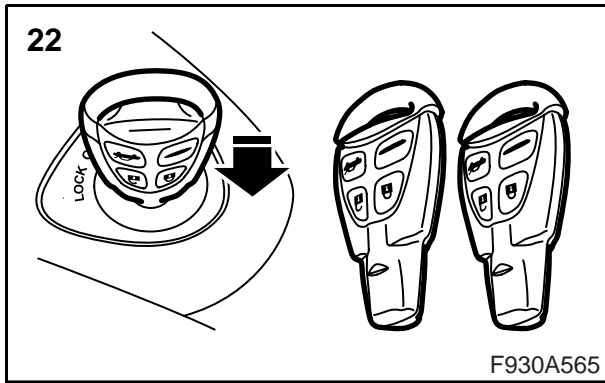

22 Synchronise the remote control code by inserting the key into the ignition switch.

Important

Alert the customer to the fact that all remote controls must be synchronised by inserting the key(s) into the ignition switch. If this is not done then the remote control will not work.

23 Cars with Anti-Pinch, 4D/5D

Learn Anti-Pinch:

WARNING

Anti-Pinch is not active until the power windows have been calibrated following power disconnection.

- 23.1 Close the doors.
- 23.2 Start the car.
- 23.3 Open the side window approx. 15 cm.
- 23.4 Depress the button and the window will now lower on its own.
- 23.5 Raise the window fully and hold the button in position for at least 1 second after the window has stopped.
- 23.6 Wait for at least 1 second.
- 23.7 Raise the window fully and hold the button in position until an audible confirmation is given.

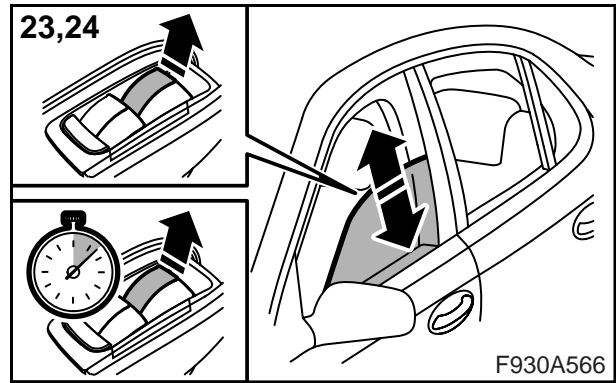

24 Cars with Anti-Pinch, CV

Learn Anti-Pinch:

WARNING

Anti-Pinch is not active until the power windows have been calibrated following power disconnection.

- 24.1 Close the doors and the soft top.
- 24.2 Start the car.
- 24.3 Depress and hold the soft top switch in position until an audible confirmation is given.

9-3 M07-, radio

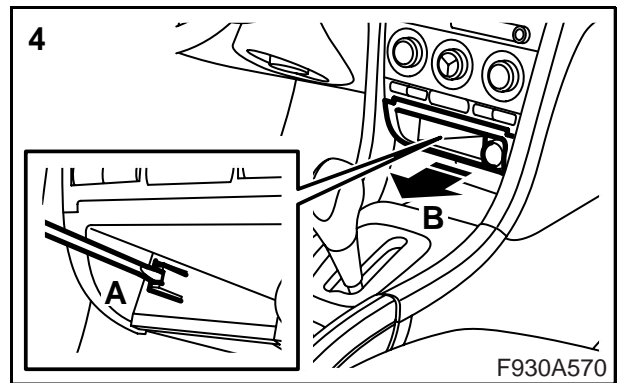
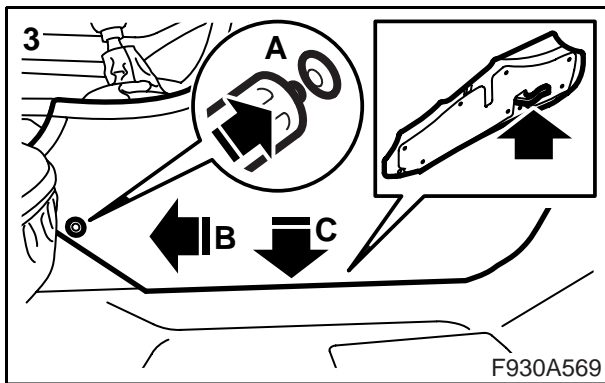
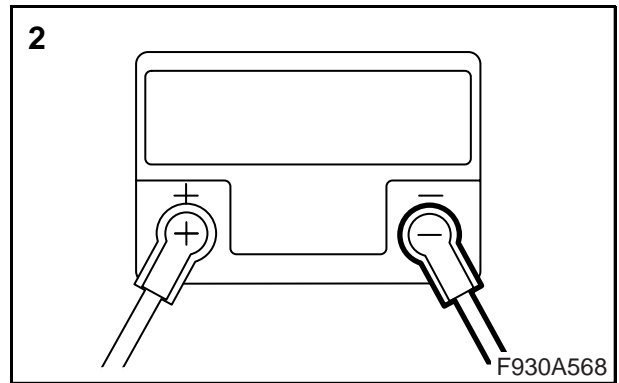
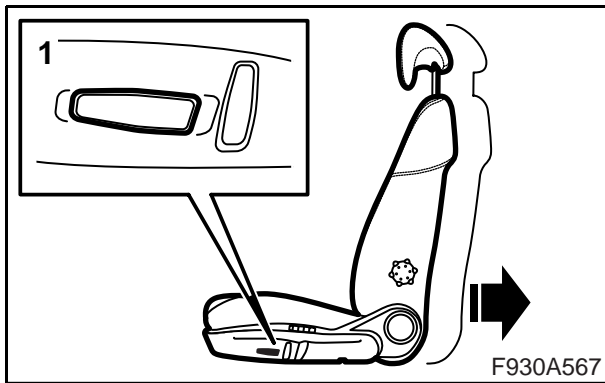

- 1 Move the passenger seat to its rearmost position.
- 2 Disconnect the battery negative cable (-).
- 3 Remove the floor console's front side protection.
- 4 Remove the ashtray/storage compartment.

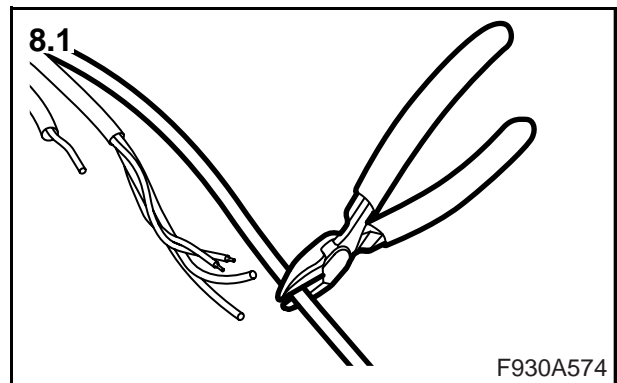
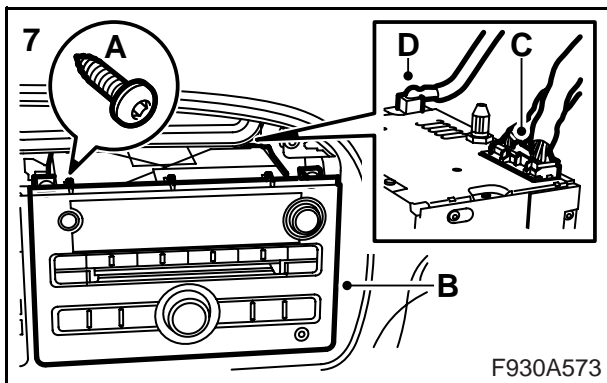
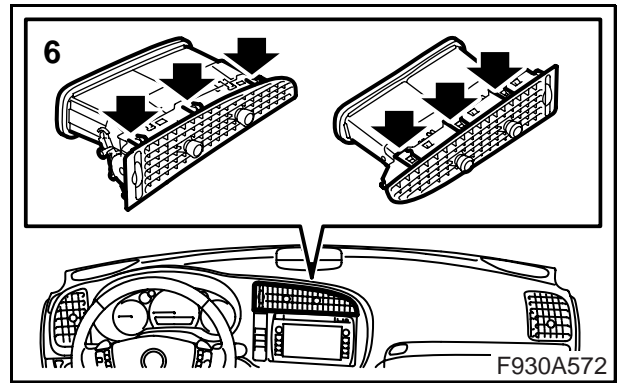
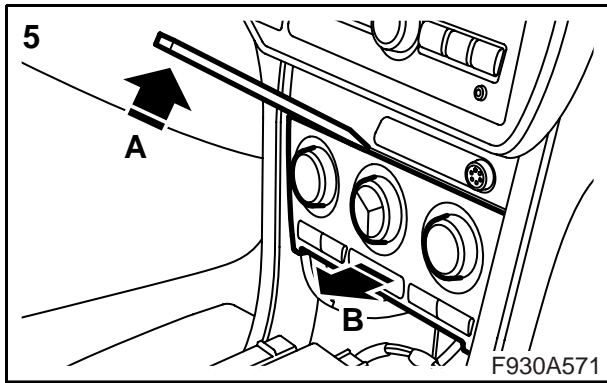

5 Remove the ACC unit.

6 Remove the centre air vent in the dashboard by carefully bending in the hooks (A) accessible through the grille.

Important

Take care to bend the correct hooks (A). Hooks holding together the air vents are also visible behind the grille.

7 Remove the retaining screws (A), lift out the radio/navigation unit (B), unplug the connectors (C) and disconnect the antenna cable (D).

Important

Exercise caution when the connector locking catch is detached to avoid damaging the connector. Pull the connector straight out when it is unplugged, to avoid bending the pins.

8 Prepared adapter harness (32 025 898):

8.1 Cut the yellow (YE) cable to the same length as the other cables in the adapter harness.

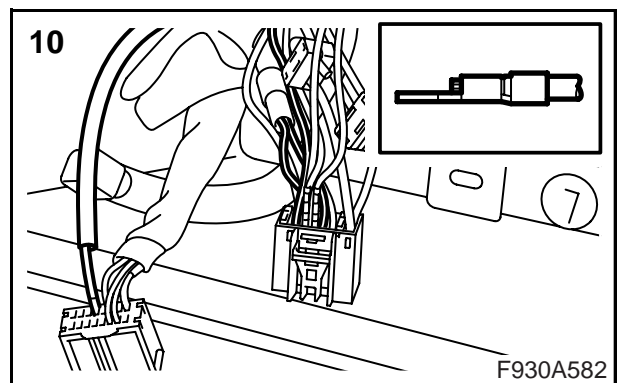
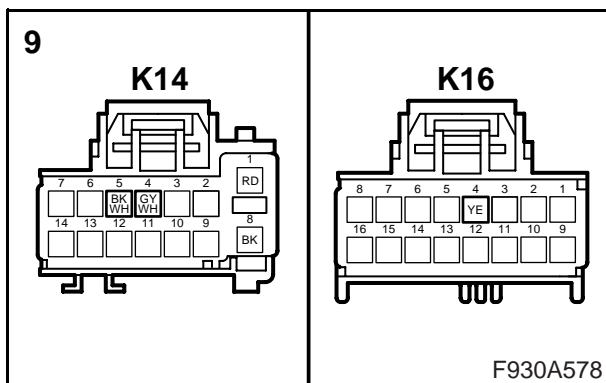
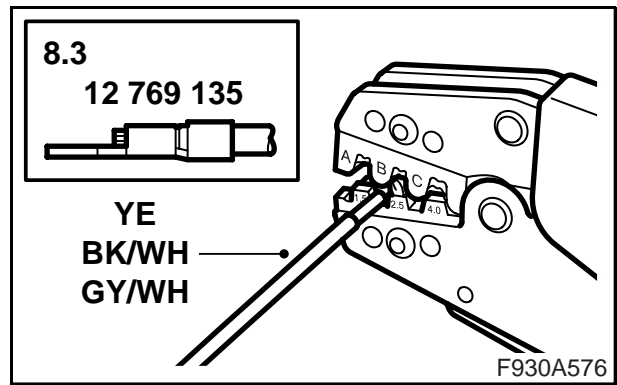
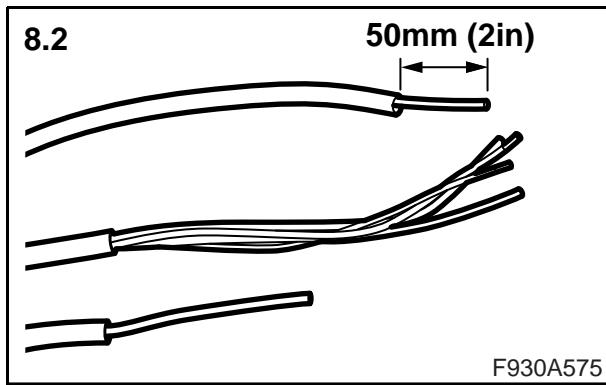

8.2 Cut the sheathing to approx. 50 mm and strip the cable end.

8.3 Crimp the cable terminals (12 769 135) to the black/white (BK/WH), grey/white (GY/WH) and yellow (YE) cable ends on the adapter harness.

Important

It is very important that the correct recess in the pliers is used. Check that the cable terminal is firmly secured.

9 Connector, overview.

10 Connect the adapter harness to the car:

10.1 BK/WH -> K14 pos 5 (line gnd)

10.2 GY/WH -> K14 pos 4 (line out)

10.3 YE -> K16 pos 4 (mute)

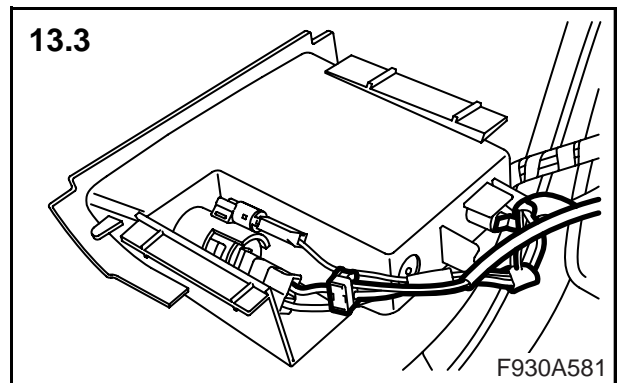
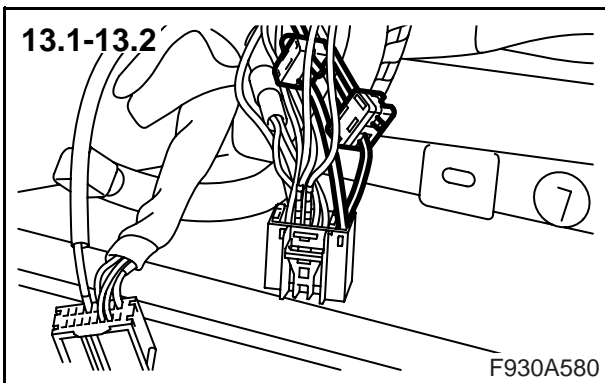
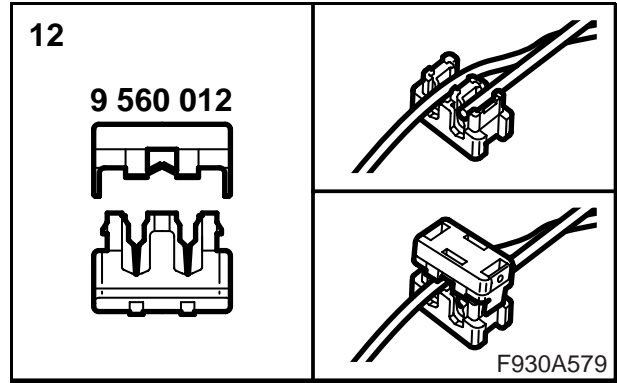
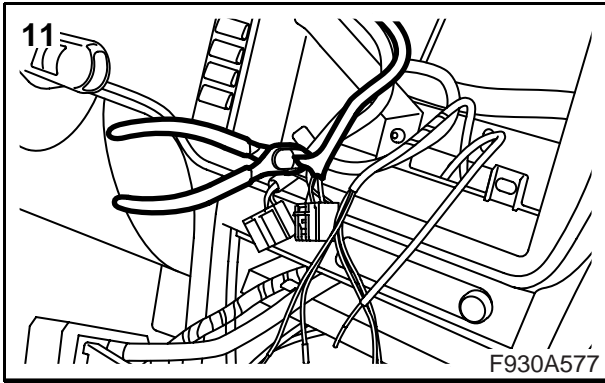

11 Release the wiring by cutting the tape approx. 50 mm from the connectors.

12 Splicing the wiring harness.

Important

In order to avoid damaging the wiring harness when splicing, the joining sleeve must only be clamped in once.

13 Connect the adapter harness to the car using joining sleeves:

13.1BK -> K14 pos 8 (gnd)

13.2RD -> K14 pos 1 (+30)

13.3RD/BU -> 12 V socket VT/BU (+15)

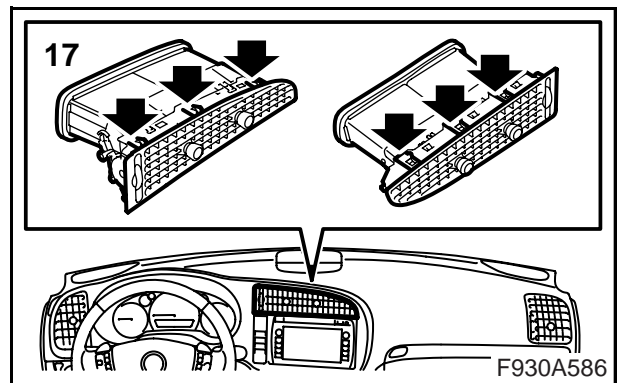
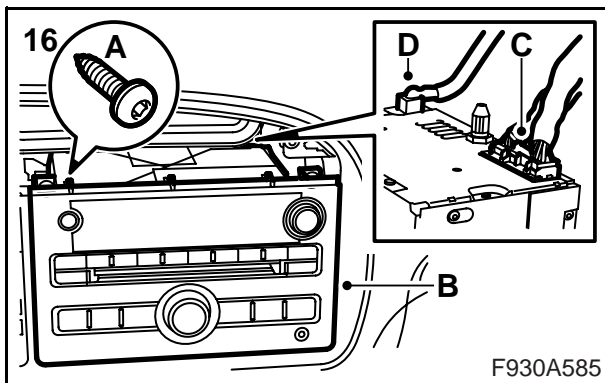
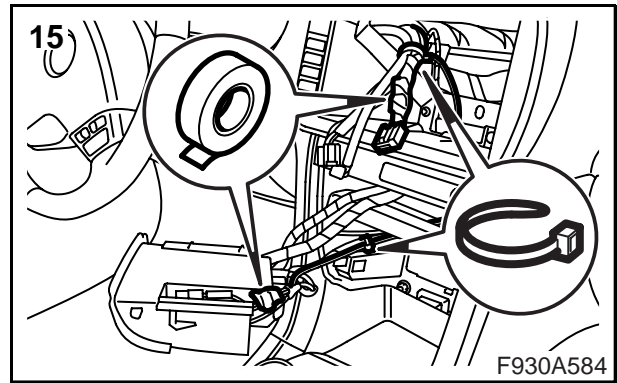
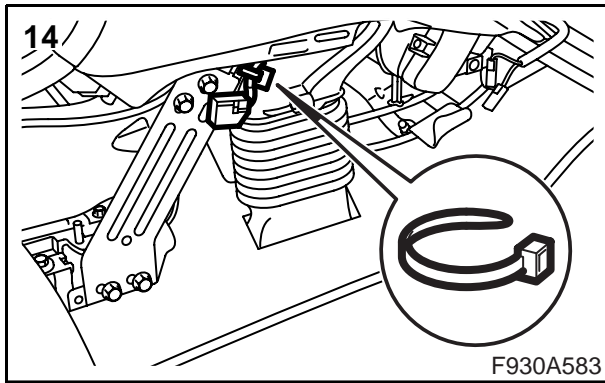

14 Align the wiring harness connector at the centre console's support and secure.

Important

Fasten the wiring harness correctly so that there is no risk of it chafing or rattling.

15 Protect the joints by insulating with fabric tape around the wiring harness. Secure the wiring harness.

Important

Fasten the wiring harness correctly so that there is no risk of it chafing or rattling.

16 Plug in the connectors for the radio's head unit (C+D), fit the radio/navigation unit (B), and fit the retaining screws (A).

17 Fit the air vent.

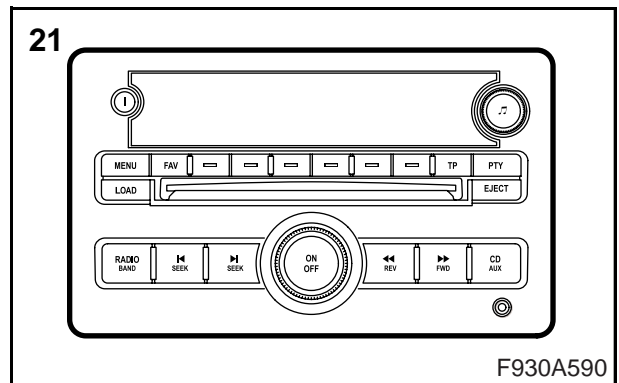
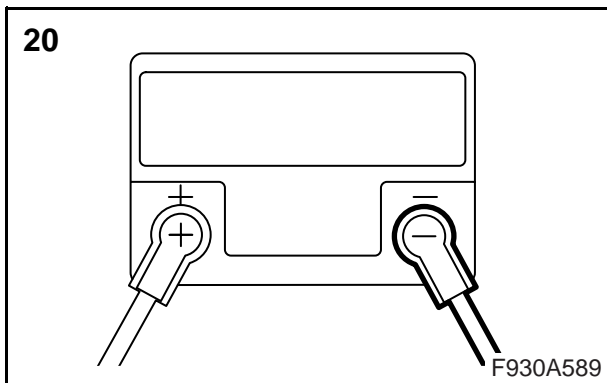
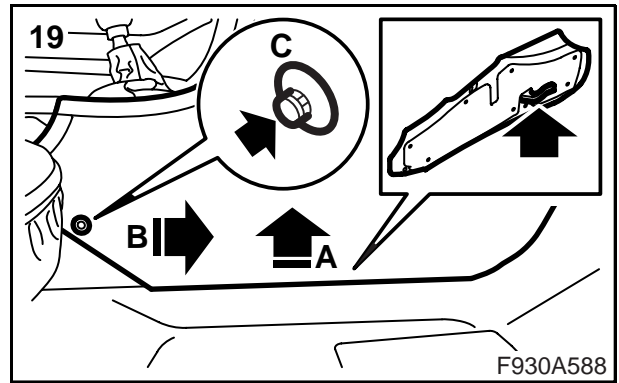
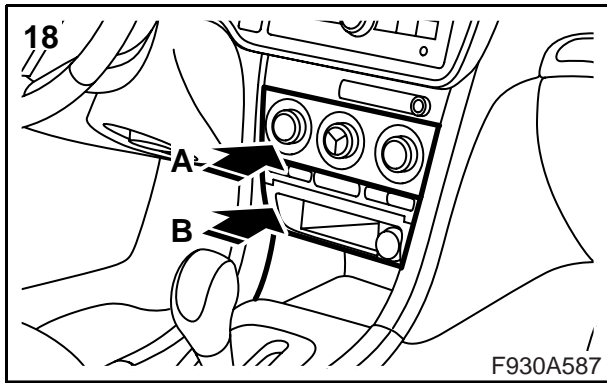

18 Fit the ACC unit (A) and the storage compartment/ashtray (B).

19 Fit the floor console's front side protection.

20 Connect the battery negative cable (-).

21 Set the time and date on the audio/navigation system's head unit:

21.1 Cars without CD-changer:

21.2 Press the Clock button. Press the menu button directly underneath the menu option you wish to change. Press the menu button again to increase time or date one increment at a time. Time and date can also be adjusted by pressing the SEEK, FWD or REV buttons.

21.3 Cars with CD-changer:

21.4 Press the MENU button. Press the menu button directly underneath the clock symbol in the display. Press the menu button directly underneath the menu option you wish to change. Press the menu button again to increase time or date one increment at a time. Time and date can also be adjusted by pressing the SEEK, FWD or REV buttons.

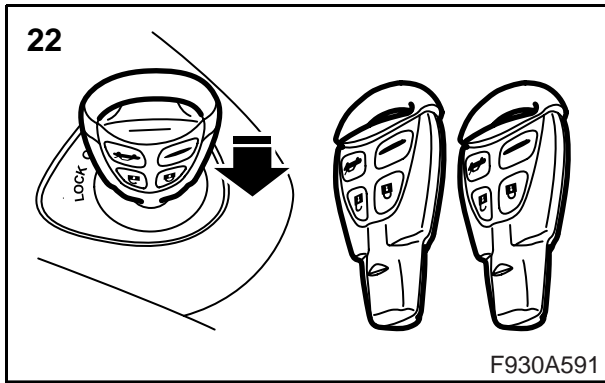

22 Synchronise the remote control code by inserting the key into the ignition switch.

Important

Repeat this procedure with all keys. Otherwise, the remote controls will not function.

23 Cars with Anti-Pinch, 4D/5D:

Learn Anti-Pinch:

WARNING

Anti-Pinch is not active until the power windows have been calibrated following power disconnection.

- 23.1 Close the doors.
- 23.2 Start the car.
- 23.3 Open the side window approx. 15 cm.
- 23.4 Depress the button and the window will now lower on its own.
- 23.5 Raise the window fully and hold the button in position for at least 1 second after the window has stopped.
- 23.6 Wait for at least 1 second.
- 23.7 Raise the window fully and hold the button in position until an audible confirmation is given.

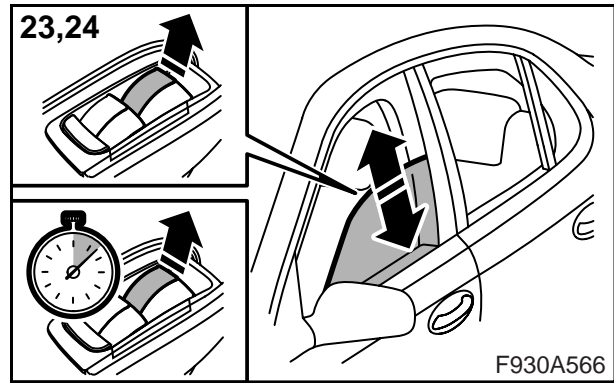

24 Cars with Anti-Pinch, 4D/5D: , CV:

Learn Anti-Pinch:

WARNING

Anti-Pinch is not active until the power windows have been calibrated following power disconnection.

- 24.1 Close the doors and the soft top.
- 24.2 Start the car.
- 24.3 Depress and hold the soft top switch in position until an audible confirmation is given.

9-3 M07-, navigation

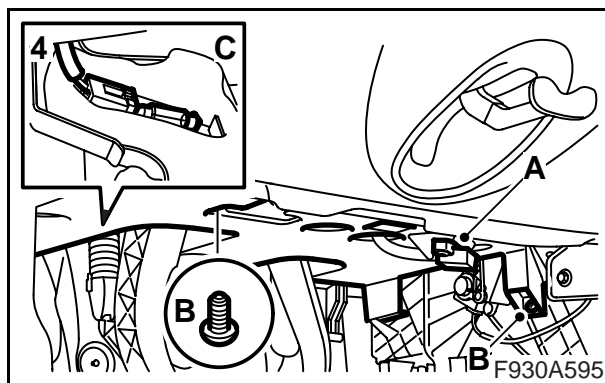
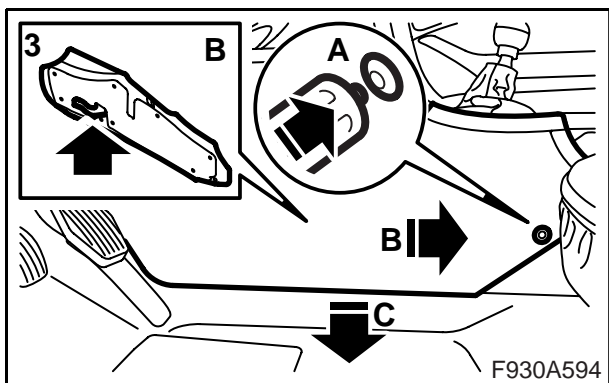
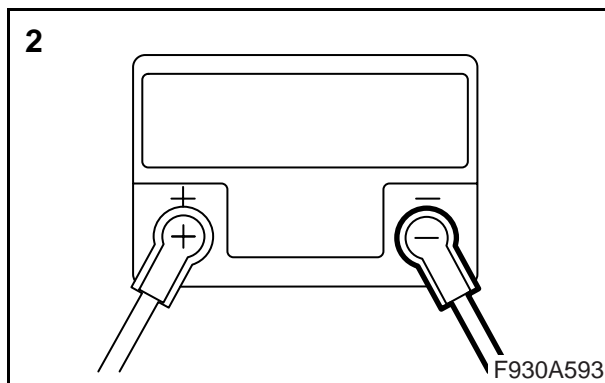
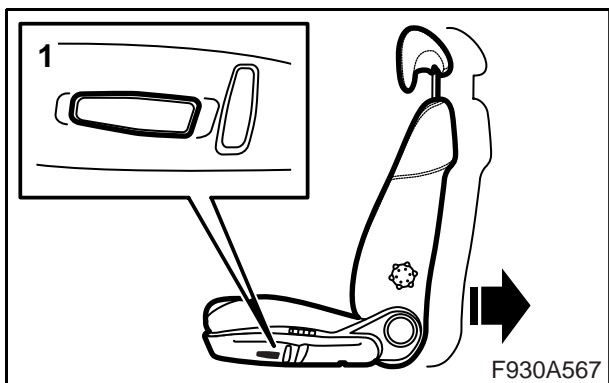

- 1 Move the driver's seat to its rearmost position.
- 2 Disconnect the battery negative cable (-).
- 3 Remove the floor console's side piece by moving it back and down.
- 4 Remove the data link connector (A), the sound insulation panel (B) and the floor lighting (C).

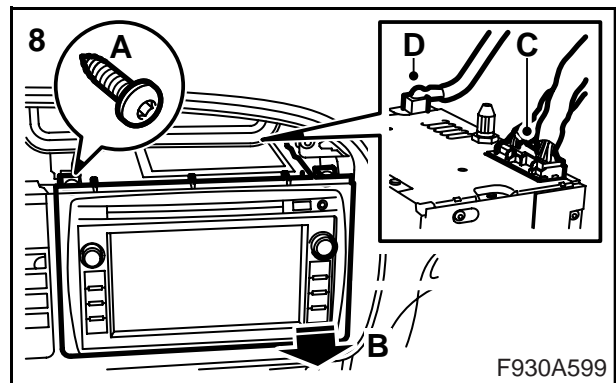
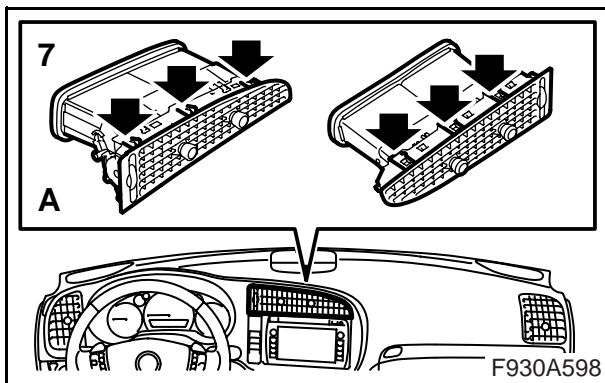
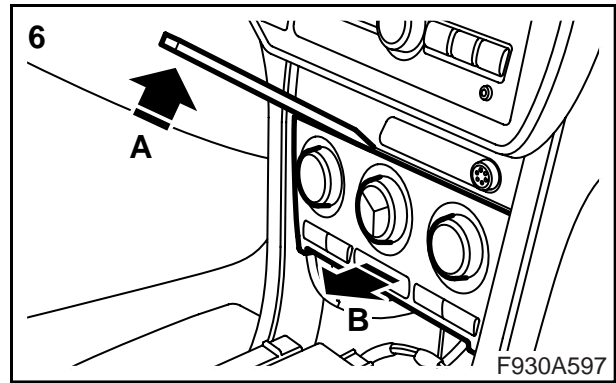
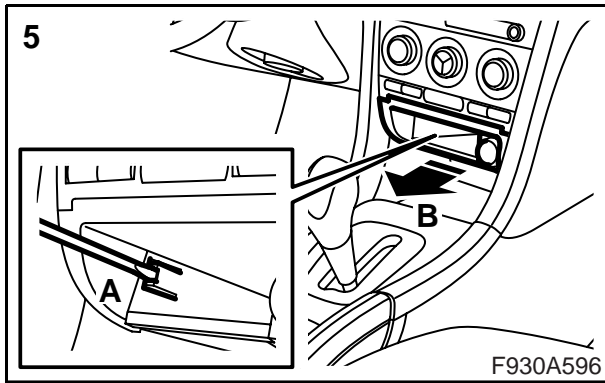

5 Remove the storage compartment/ashtray using a screwdriver.

6 Remove the ACC unit.

7 Remove the centre air vent in the dashboard by carefully bending in the hooks (A) accessible through the grille.

Important

Take care to bend the correct hooks (A). Hooks holding together the air vents are also visible behind the grille.

8 Remove the retaining screws (A), lift out the radio/navigation unit (B), unplug the connectors (C) and disconnect the antenna cable (D).

Important

Exercise caution when the connector locking catch is detached to avoid damaging the connector. Pull the connector straight out when it is unplugged, to avoid bending the pins.

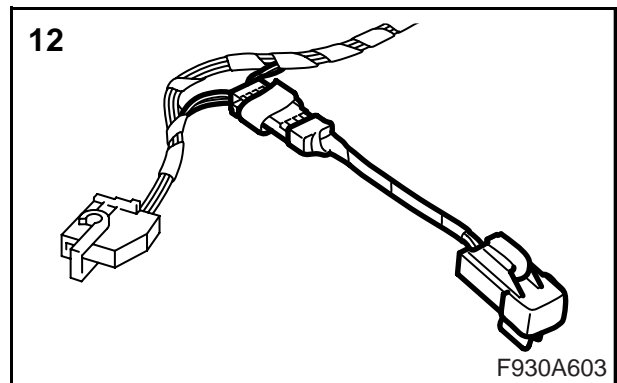
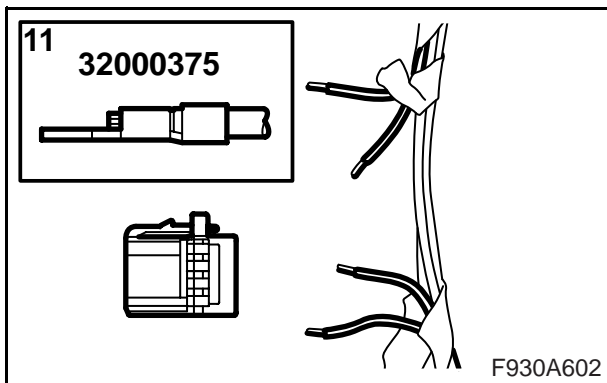
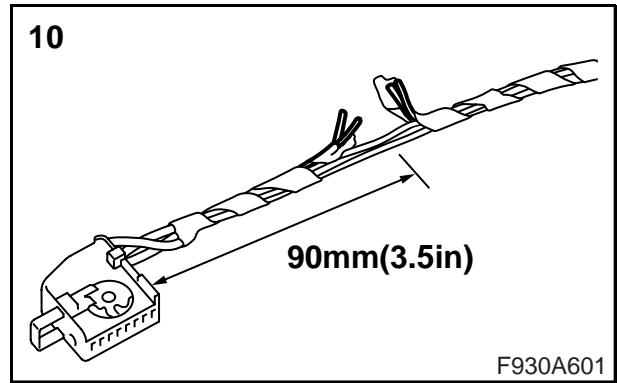
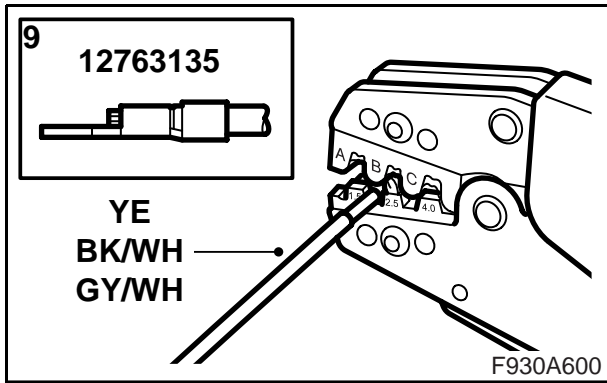

- 9 Crimp the cable terminals (32 000 375) to the black/white (BK/WH), grey/white (GY/WH) and yellow (YE) cable ends on the adapter harness.

Important

It is very important that the correct recess in the pliers is used. Check that the cable terminal is firmly secured.

- 10 Cut several centimetres of the tape approx. 90 mm (3.5 in) from the connector on the adapter harness. Cut the grey/white (GY/WH) and black/white (BK/WH) cable approx. 90 mm (3.5 in) from the connector.
- 11 Plug in the connector (12 789 432) to the adapter harness:
- 11.1 Crimp the cable terminals (32 000 375) on the cable ends.
- 11.2 Connect: GY/WH -> 1 (to the connector)
BK/WH -> 2 (to the connector) GY/WH -> 3
BK/WH -> 4.
- 12 Connect the resistor (12 769 716) to the adapter harness:

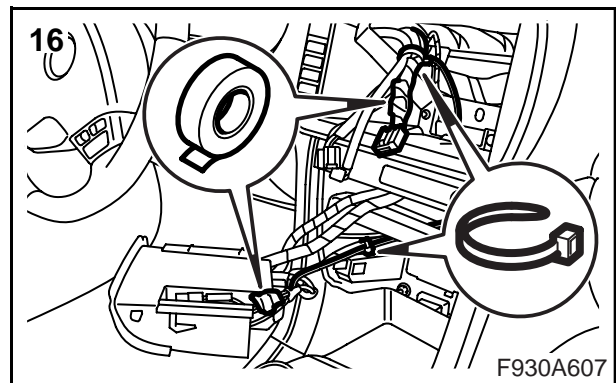
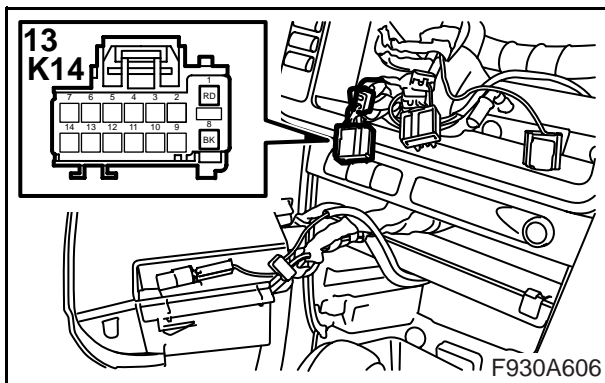
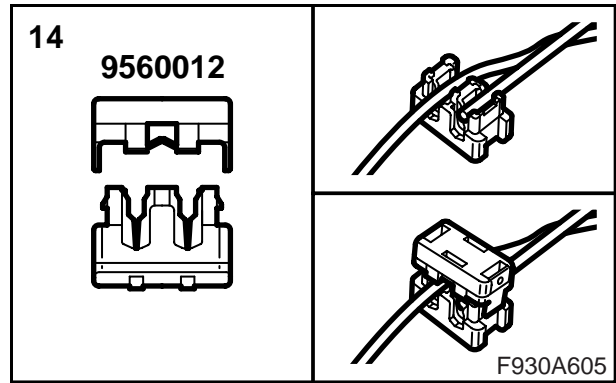
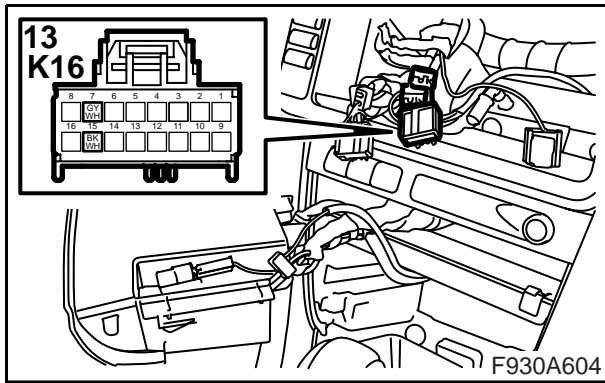

13 Connect the adapter harness to the car:

13.1GY/WH -> K16 pos 7 (line out)

13.2BK/WH -> K16 pos 15 (line gnd)

14 Splicing the wiring harness.

Important

In order to avoid damaging the wiring harness when splicing, the joining sleeve must only be clamped in once.

15 Connect the adapter harness to the car using joining sleeves:

RD -> K14 pos 1 (+30)

BK -> K14 pos 8 (gnd)

RD/BU -> 12 V socket BU/VI (+15)

16 Position the wiring harness connector by the centre console's support. Protect the joints by insulating with fabric tape around the wiring harness and secure the wiring harness.

Important

Fasten the wiring harness correctly so that there is no risk of it chafing or rattling.

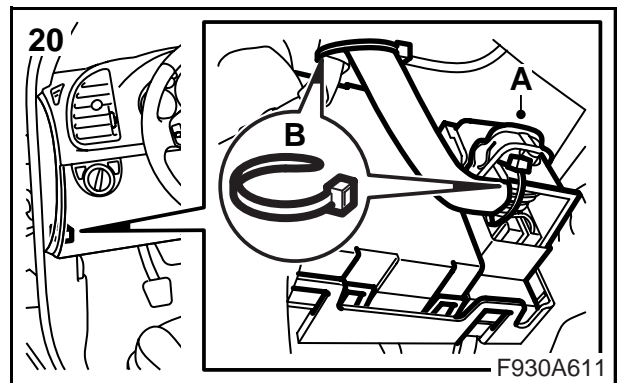
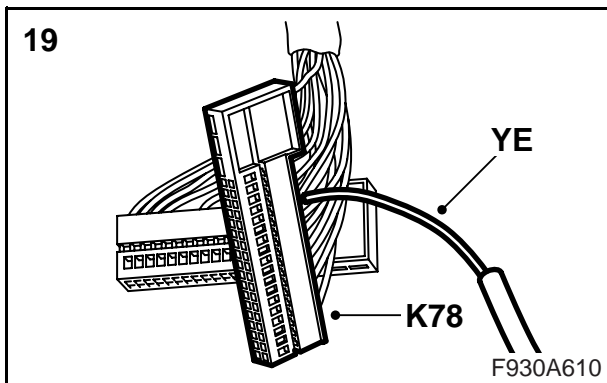
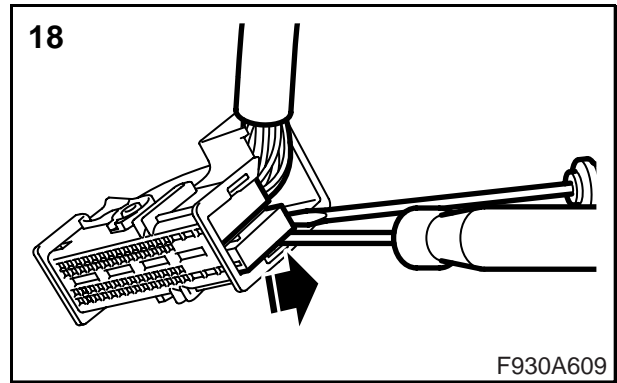
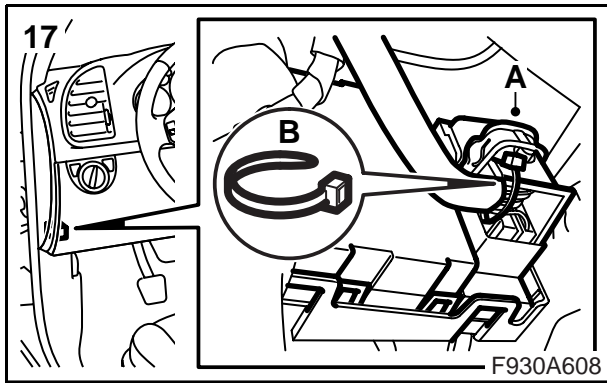

- 17 Fold up the catch (A), cut the cable tie (B) and remove the BCM plug.
- 18 Unplug the connector from the plug, prize apart and pull out.
- 19 Connect the yellow (YE) cable from the adapter harness to the BCM K78 (grey connector) pos 35 (mute).
- 20 Plug in the connectors to the plug, connect the plug (A) and secure with cable ties (B).

Important

Fasten the wiring harness correctly so that there is no risk of it chafing or rattling.

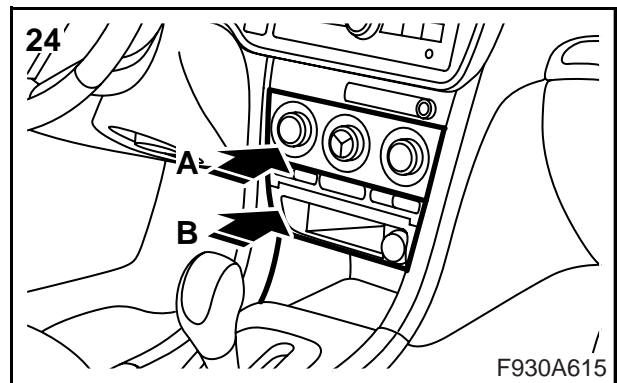
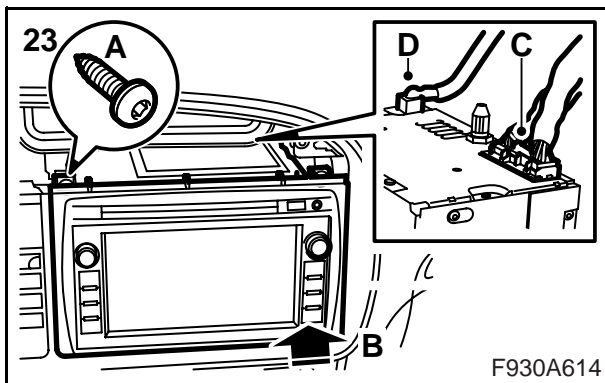
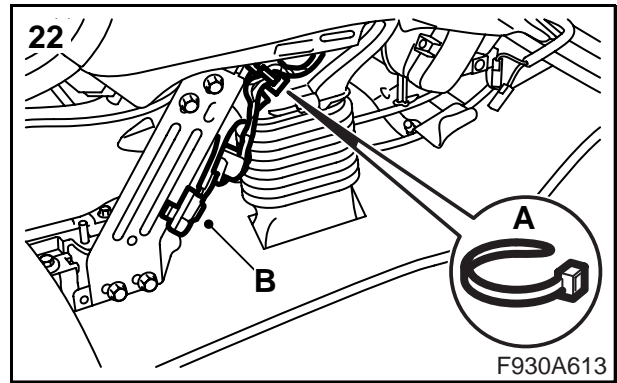
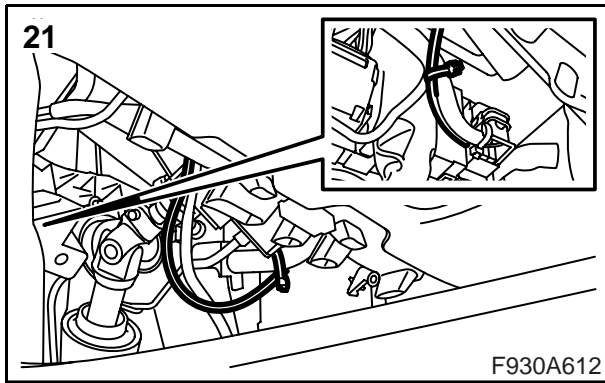

21 Secure the adapter harness with cable ties.

Important

Fasten the wiring harness correctly so that there is no risk of it chafing or rattling.

22 Route the adapter harness on the right-hand side of the centre console and secure with cable tie (A) and clip (B).

Important

Fasten the wiring harness correctly so that there is no risk of it chafing or rattling.

23 Plug in the connectors for the radio's head unit (C+D), fit the radio/navigation unit (B), and fit the retaining screws (A).

24 Fit the ACC unit (A) and the storage compartment/ashtray (B).

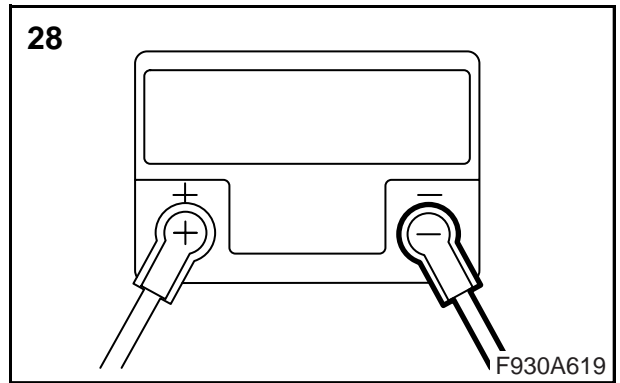
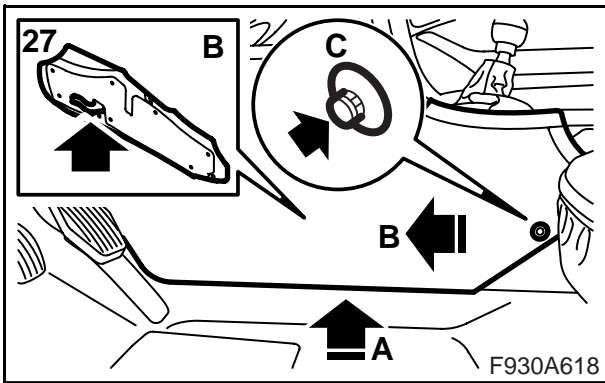
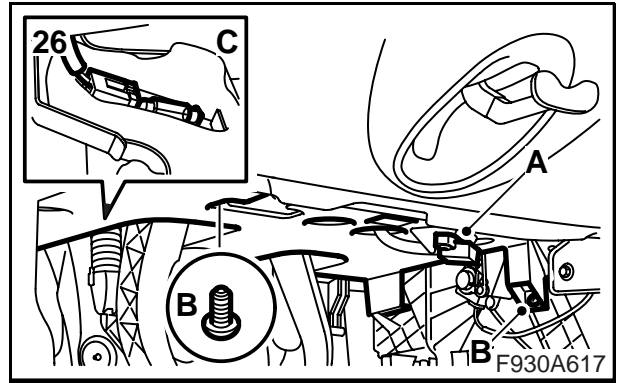
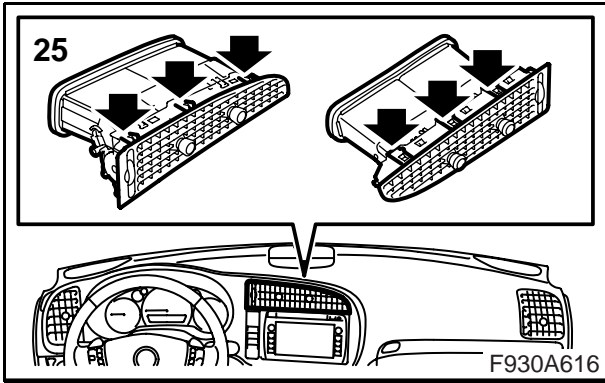

- 25 Fit the air vent.
- 26 Fit the floor lighting (C), the sound insulation panel (B) and the data link connector (A).
- 27 Fit the floor console's side piece.
- 28 Connect the battery negative cable (-).

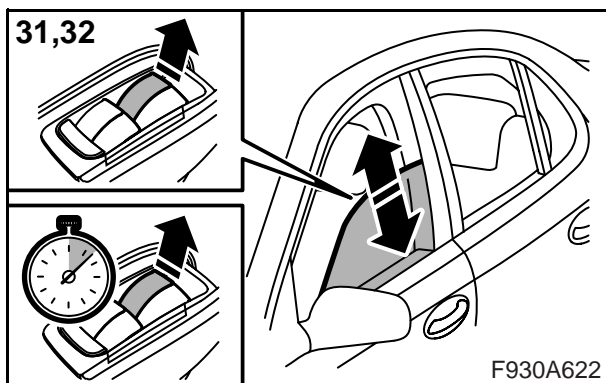
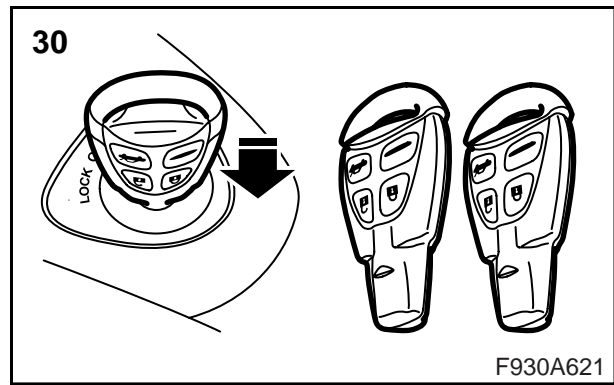
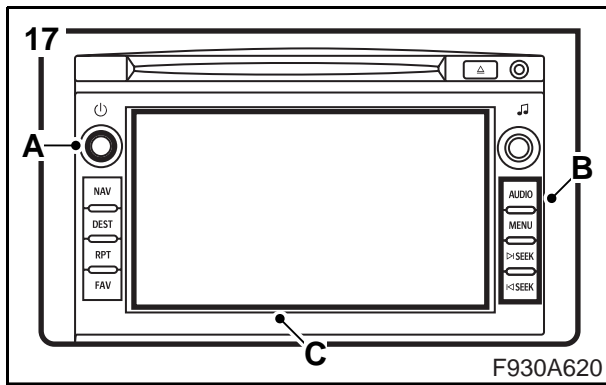

29 Set the time:

Note

This unit has a touch panel and only displays the time.

- 29.1 Ignition in ON position.
- 29.2 Activate the radio (A).
- 29.3 Press MENU (B) until the tab for the clock is activated.
- 29.4 Follow the instructions on the screen (C).

30 Synchronise the remote control code by inserting the key into the ignition switch.

Important

Repeat this procedure with all keys. Otherwise, the remote controls will not function.

31 **Cars with Anti-Pinch, 4D/5D:**

Learn Anti-Pinch:

WARNING

Anti-Pinch is not active until the power windows have been calibrated following power disconnection.

- 31.1 Close the doors.
- 31.2 Start the car.
- 31.3 Open the side window approx. 15 cm.
- 31.4 Depress the button and the window will now

lower on its own.

31.5 Raise the window fully and hold the button in position for at least 1 second after the window has stopped.

31.6 Wait for at least 1 second.

31.7 Raise the window fully and hold the button in position until an audible confirmation is given.

32 **Cars with Anti-Pinch, CV:**

Learn Anti-Pinch:

WARNING

Anti-Pinch is not active until the power windows have been calibrated following power disconnection.

32.1 Close the doors and the soft top.

32.2 Start the car.

32.3 Depress and hold the soft top switch in position until an audible confirmation is given.

9-5 M06-, radio/navigation

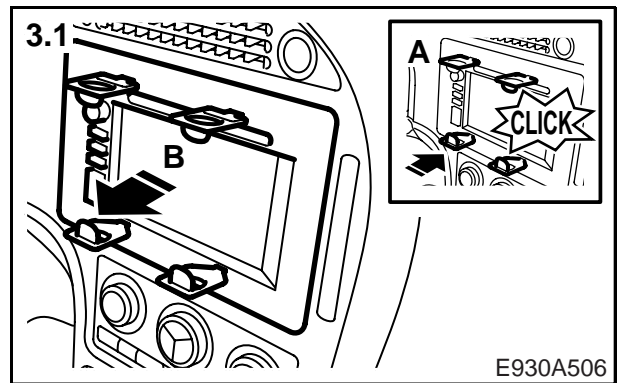
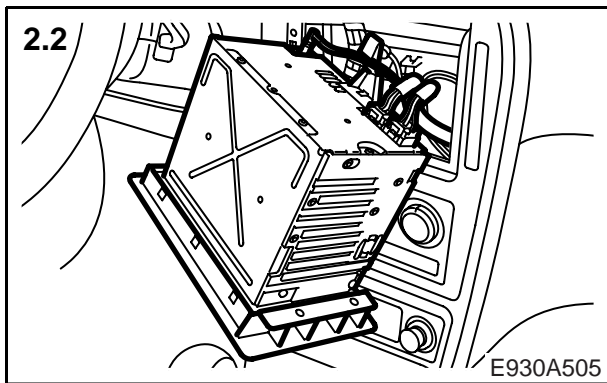
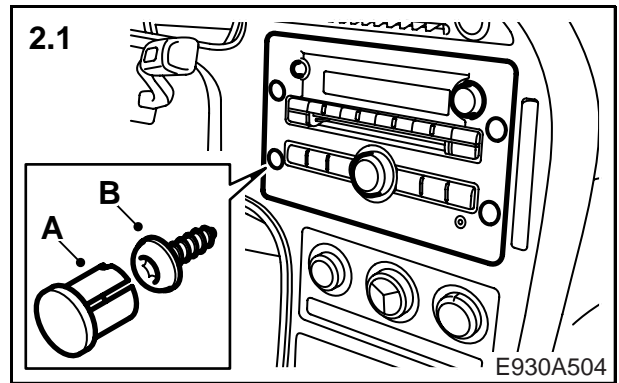
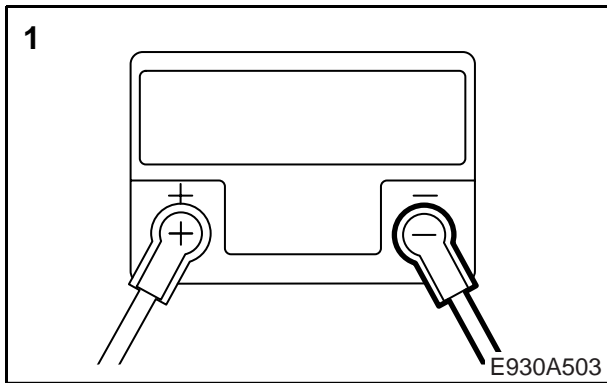

1 Disconnect the battery negative cable (-).

2 **Cars with radio:**

2.1 Remove the plugs (A) and the screws (B).

Important

Remove the plugs by attaching tape on the plug and then remove it.

2.2 Lift out the radio and unplug the connectors and disconnect the antenna connection.

3 **Cars with navigation:**

3.1 Press in the special tools until they engage. Pull out the navigation unit using the tool handles.

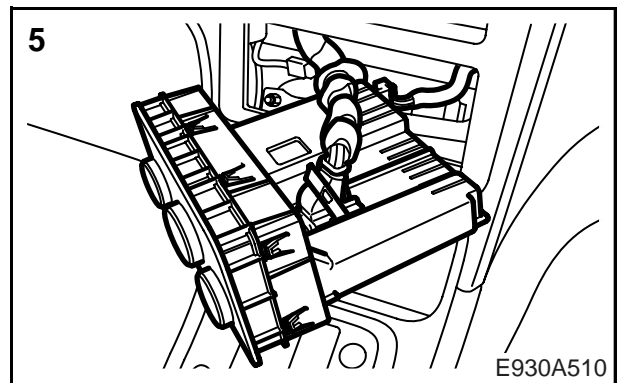
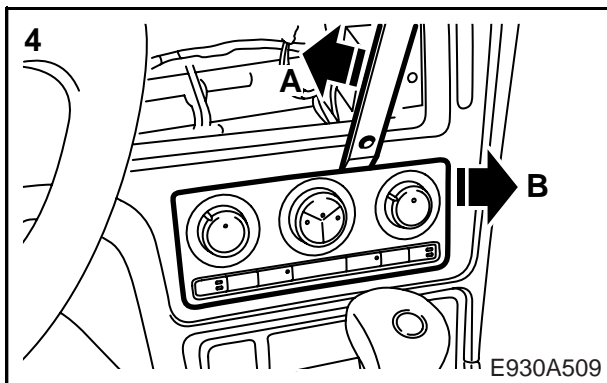
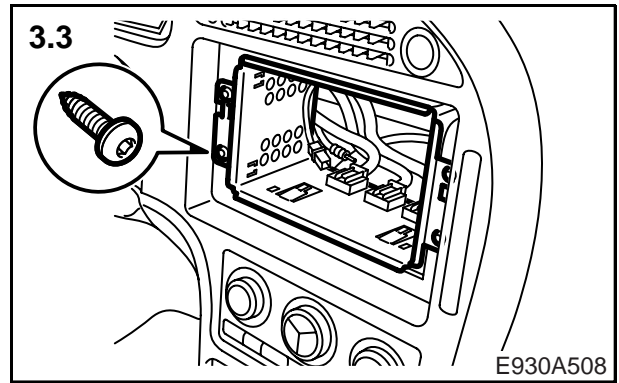
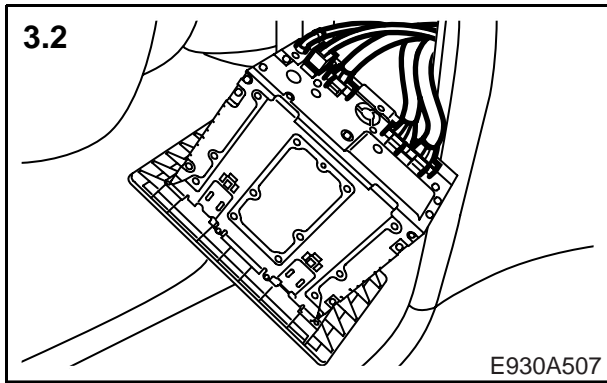

- 3.2 Unplug the navigation unit's connectors.
- 3.3 Remove the compartment.
- 4 Remove the ACC unit.
- 5 Unplug the ACC unit connectors.

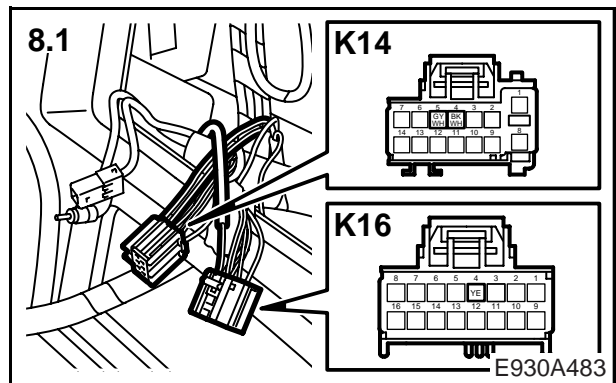
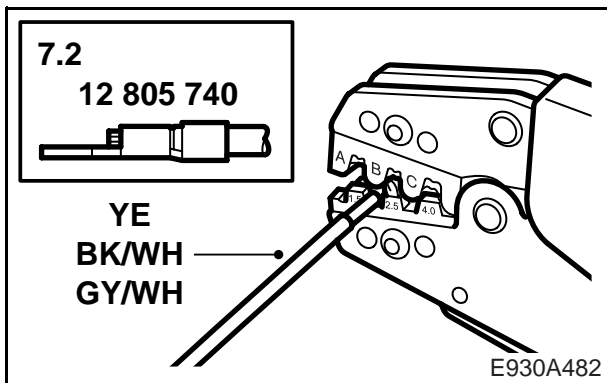
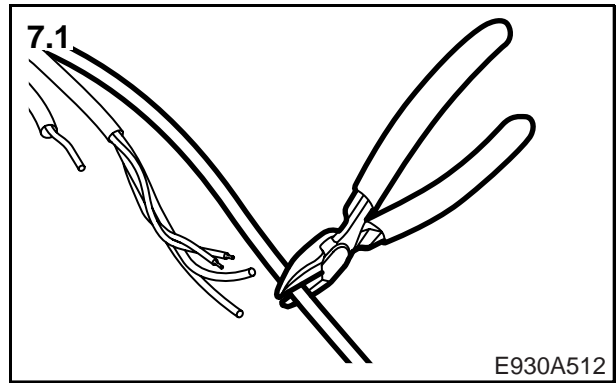
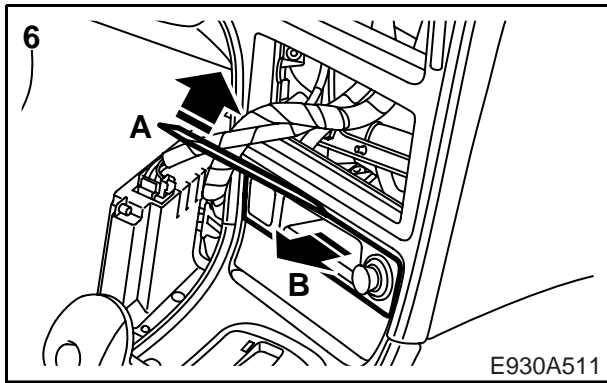

6 Remove the ashtray/storage compartment.

7 Prepared adapter harness:

Important

Check that the cable terminal is firmly secured.

7.1 Cut the yellow (YE) cable to the same length as other cables in the adapter harness (A). Cut the sheathing approx. 5 cm and strip the cable end.

7.2 Connect the cable terminals (12 805 740) to the yellow (YE), black/white (BK/WH) and grey/white (GY/WH) cable ends on the adapter harness.

8 **Cars with radio:** Connect the adapter harness to the car:

8.1 Connect with cable terminals:

Yellow (YE) -> K16 pos 4 (mute)

Black/white (BK/WH) -> K14 pos 4 (line ground)

Grey/white (GY/WH) -> K14 pos 5 (line out)

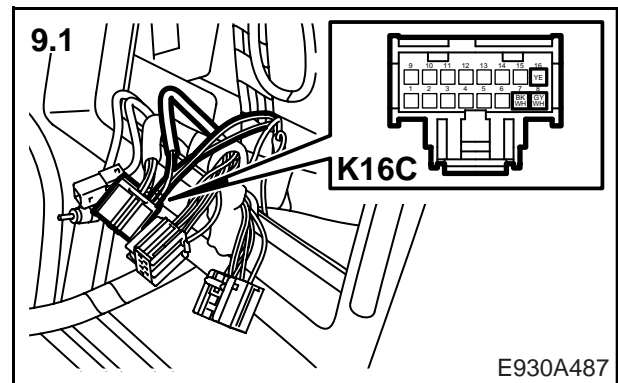
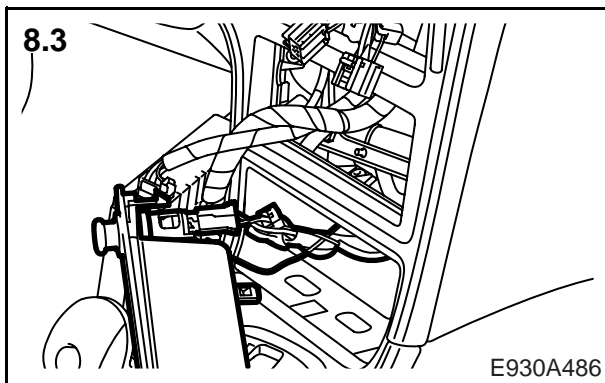
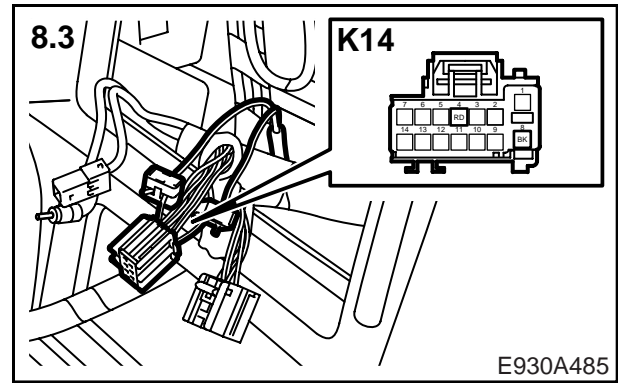
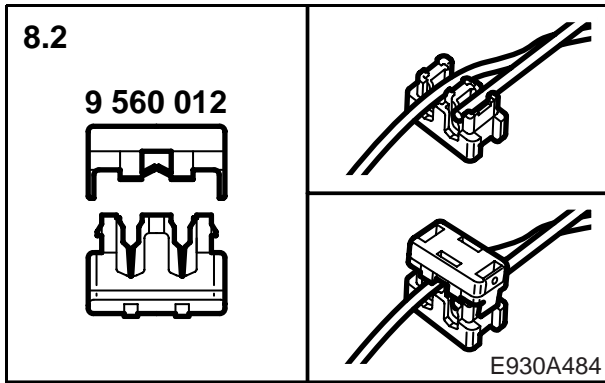

8.2 Splicing the wiring harness.

Important

In order to avoid damaging the wiring harness when splicing, the joining sleeve must only be clamped in once.

8.3 Connect the adapter harness with joining sleeves:

Red (RD) -> K14 pos 1 (+30)

Black (BK) -> K14 pos 8 (ground)

Red/blue (RD/BU) -> 12 V socket brown (BN) (+15)

9 **Cars with navigation:** Connect the adapter harness to the car:

9.1 Connect with cable terminals:

Black/white (BK/WH) -> K16C pos 7 (line ground)

Grey/white (GY/WH) -> K16C pos 8 (line out)

Yellow (YE) -> K16C pos 16 (mute)

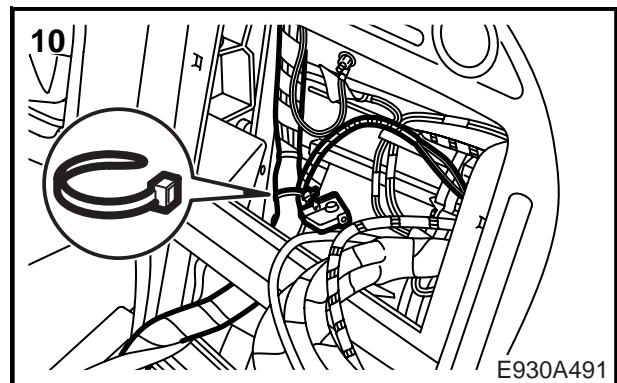
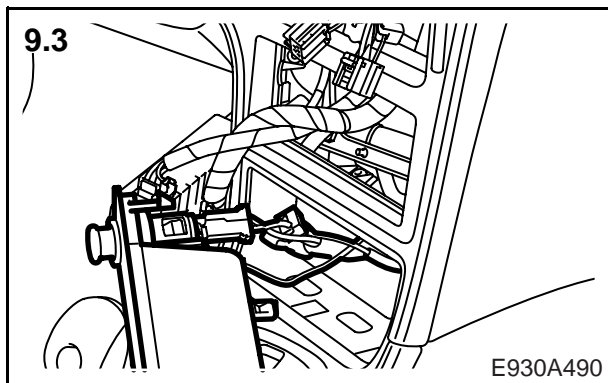
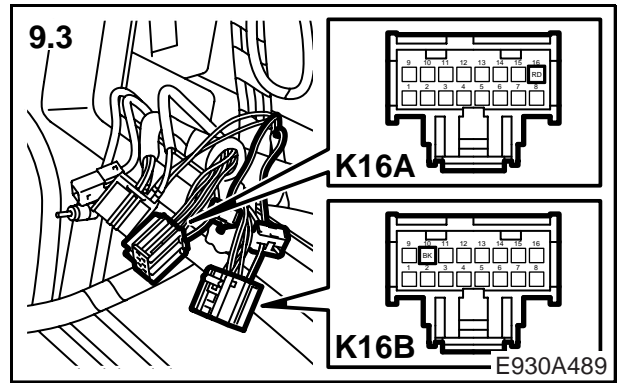
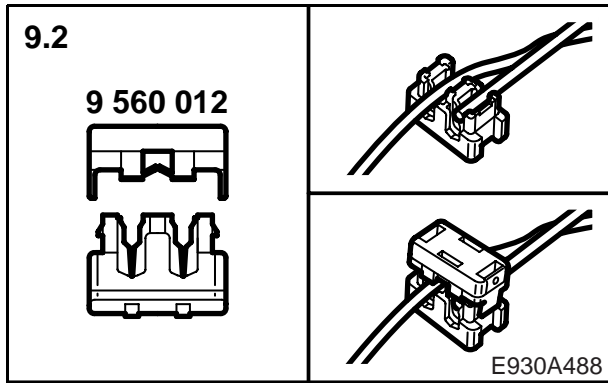

9.2 Splicing the wiring harness.

Important

In order to avoid damaging the wiring harness when splicing, the joining sleeve must only be clamped in once.

9.3 Connect the adapter harness with joining sleeves:

- Red (RD) -> K16A pos 16 (+30)
- Black (BK) -> K16B pos 10 (ground)
- Red/blue (RD/BU) -> 12 V socket brown (BN) (+15)

10 Secure the Tel1 connection with cable ties.

Important

Fasten the wiring harness correctly so that there is no risk of it chafing or rattling.

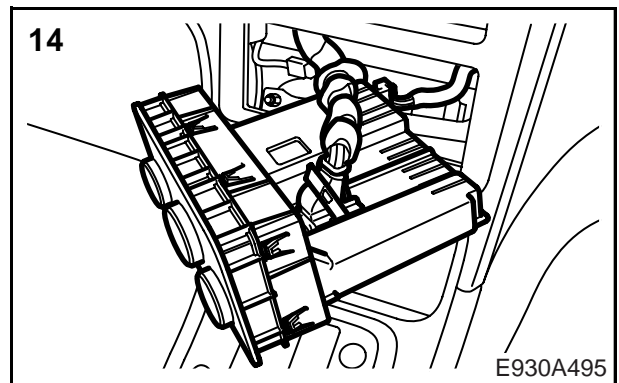
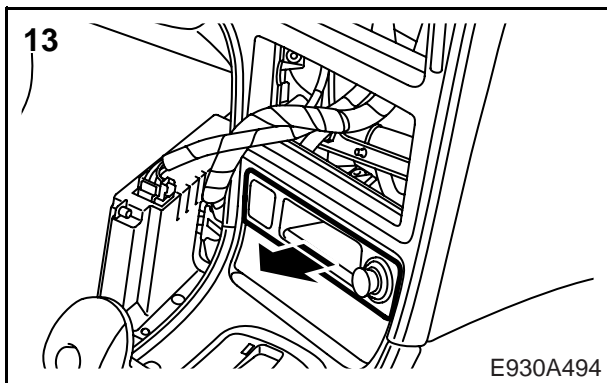
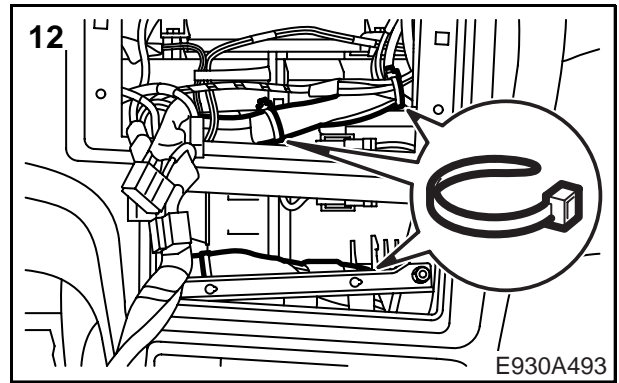
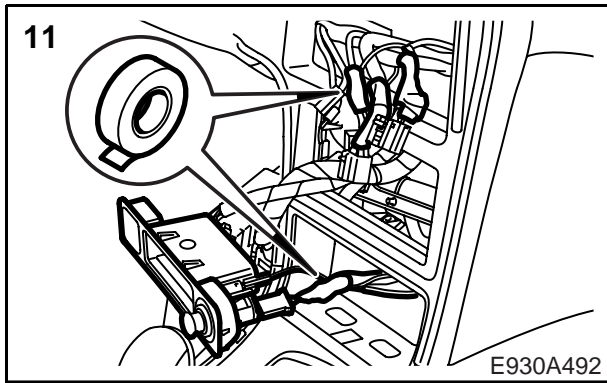

11 Protect the joints by insulating with fabric tape around the wiring harness.

12 Secure the wiring and any excess.

Important

Fasten the wiring harness correctly so that there is no risk of it chafing or rattling.

13 Fit the ashtray/storage compartment.

14 Plug in the connectors and fit the ACC unit.

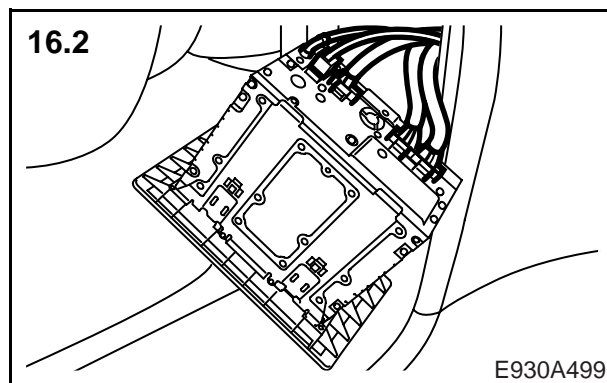
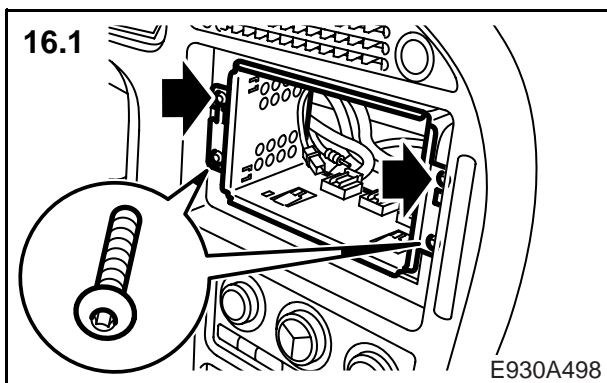
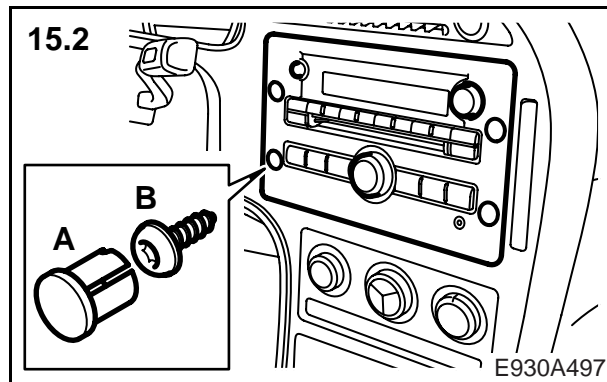
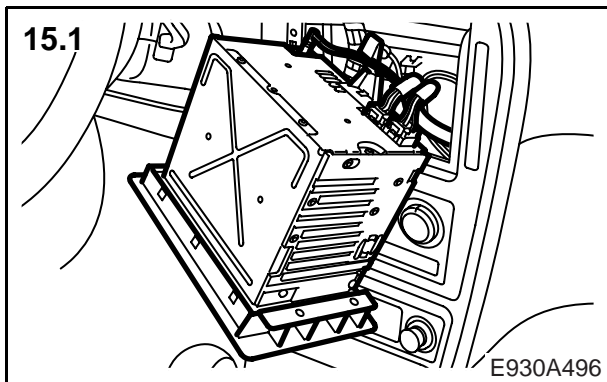

15 Cars with radio:

15.1 Plug in the radio unit's connectors, connect the antenna connection and insert the unit.

15.2 Fit the screws (B) and the plugs (A).

16 Cars with navigation:

16.1 Fit the compartment.

16.2 Plug in the navigation unit's connectors, connect the antenna connection and insert the unit.

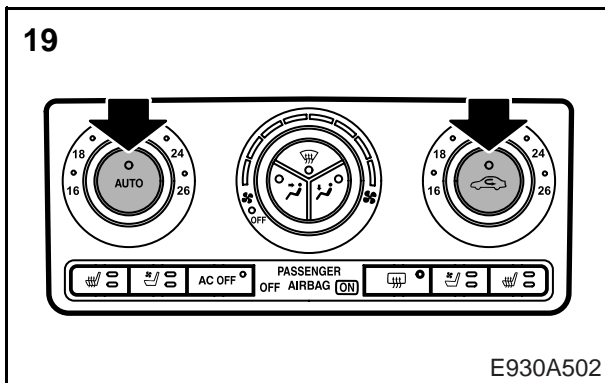
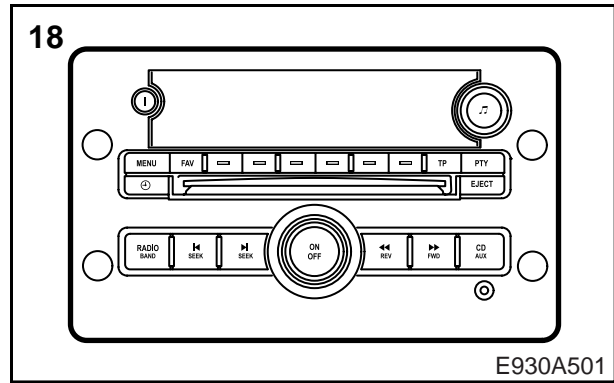
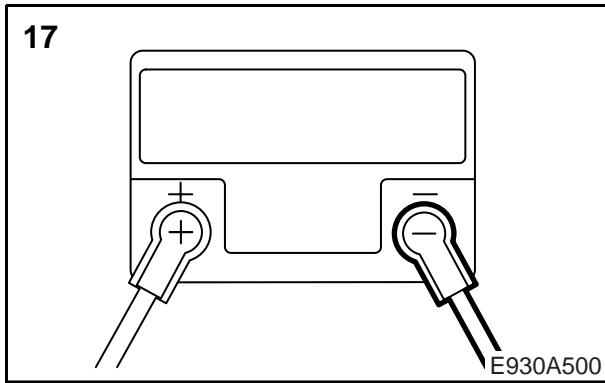

- 17 Connect the battery negative cable (-).
- 18 Set the time and date on the audio/navigation system's head unit:

18.1 Cars without CD-changer:

18.2 Press the Clock button. Press the menu button directly underneath the menu option you wish to change. Press the menu button again to increase time or date one increment at a time. Time and date can also be adjusted by pressing the SEEK, FWD or REV buttons.

18.3 Cars with CD-changer:

18.4 Press the MENU button. Press the menu button directly underneath the clock symbol in the display. Press the menu button directly underneath the menu option you wish to change. Press the menu button again to increase time or date one increment at a time. Time and date can also be adjusted by pressing the SEEK, FWD or REV buttons.

- 19 Calibrate the ACC system:

19.1 Start the engine.

19.2 Press in the AUTO and REC buttons until the message "ACC: CALIBR. STARTED" is shown in the main instrument unit's display. Calibration takes approx. 20 seconds.