

**SAAB****SERVICE INFORMATION**

SI No. 471-1743	Date June 1997	9000
PI No.	Distr. US, CA	

New oil for manual gearboxes

C471B001

Cars affected

All Saab 9000 M85- with manual gearbox

Background

A new gearbox oil has been introduced due to design changes and reduced face area, which puts higher demands on an oil's temperature resistance.

The new oil has several advantages, such as:

- it withstands temperatures >150°C (302 °F)
- it increases bearing service-life
- it counteracts surface damage to gear flanks
- gear-shifting is perceived as smoother, especially in cold weather
- It can be used to advantage in older gearboxes

The oil has been introduced in production from chassis no. V1021673- but it can be used to advantage when reconditioning or repairing gearboxes. In such cases, it is important to read the instructions under the heading "Procedure".

The filler plug on gearboxes from the factory that contain the new oil are marked with the text:

"USE ONLY SAAB OIL NO 8748733"

When changing the oil, the filler plug must be changed. However, the new plug does not fit on gearboxes in cars older than model year 1994.

Important

The new oil must not be mixed with other types of oil but there is no problem changing to this oil in an old gearbox as long as the instructions found under the heading "Procedure" are followed.

Parts required

- 87 48 733 (CA: 30567840) Gearbox oil
- 47.76 266 (CA: 30568130) Filler plug (M94-)

Saab Automobile AB Bulletins are intended for use by professional Saab technicians only, NOT a "do-it-yourselfer". They are designed to inform these technicians of conditions that may occur on some vehicles, or to provide information that could assist in the proper service of a vehicle. Saab trained technicians have the equipment, tools, safety instructions, and know-how to do a job properly and safely. If a condition is described, DO NOT assume that the bulletin applies to your vehicle, or that your vehicle will have the condition. See your authorized Saab Dealer for information on whether your vehicle may benefit from the information.

© 1997 Saab Automobile AB. All rights reserved.

ENG

Procedure -M93

- 1 Drain the gearbox by removing plug A and using an oil suction pump.

If there is no plug A, the speedometer drive B can be removed. Clean thoroughly around its fitting before removing it. Use tool 87 90 917 to lift up the speedometer drive from the gearbox.

- 2 Fill with 1.0 litre (1.05 quarts) of the new oil and run the car so that the oil flows thoroughly through the system.
- 3 Drain the gearbox as instructed in step 1.
- 4 Fill the gearbox with new oil to the correct level (2.5 litres; 2.6 quarts),

After this procedure, the oil does not need changing.

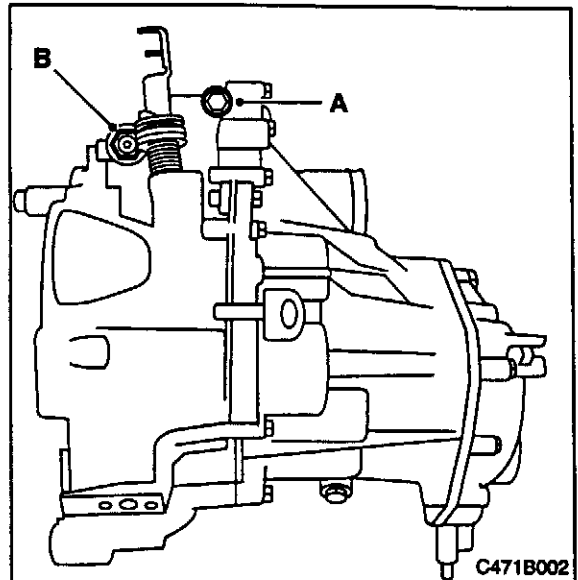

C471B002

- 5 There are two labels on the neck of the oil carton that must be affixed to separate places as a reminder of the type of oil in the gearbox.

- 6 Clean the area around the radiator crossmember by the left-hand headlamp, remove the label with the warning triangle and affix it to the radiator crossmember.

- 7 Remove the small label and affix it over the existing text on gearbox oil in the owner's manual under the section "Technical data".



C471B003

Procedure M94-

- 1 Drain the oil from the gearbox by unscrewing the drain plug (3).
 - 2 Fill with 1.0 litre (1.05 quarts) of the new oil (plug 1) and run the car so that the oil flows thoroughly through the system.
 - 3 Drain the gearbox (plug 3).
 - 4 Fill the gearbox with new oil to the correct level (1.8 litres; 1.9 quarts). Check with the level plug (2).
- After this procedure, the oil does not need changing.
- 5 Fit a new filler plug (1).

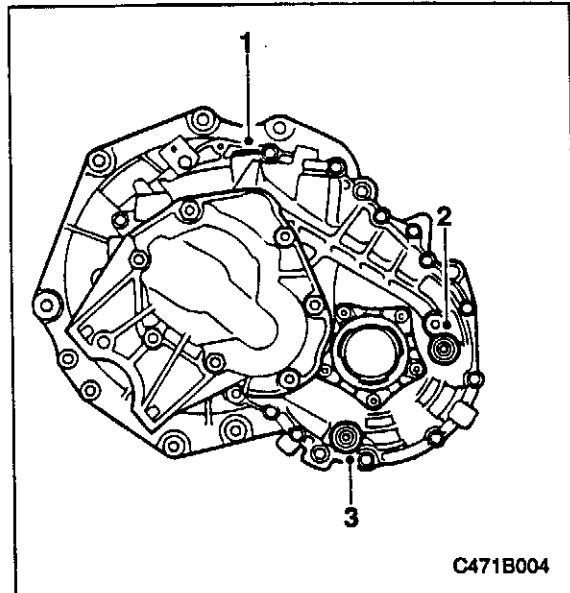

- 6 There are two labels on the neck of the oil carton that must be affixed to separate places as a reminder of the type of oil in the gearbox.
- 7 Clean the area around the radiator crossmember by the left-hand headlamp, remove the label with the warning triangle and affix it to the radiator crossmember.
- 8 Remove the small label and affix it over the existing text on gearbox oil in the owner's manual under the section "Technical data".

**Warranty conditions**

If damage to a gearbox replaced under warranty is found to have been caused by oil NOT approved by Saab, the entire claim will be subject to charge back.