

Brake pads, rear wheel, swinging caliper**To check**

Since the brakes are self-adjusting, it is not possible to tell from the amount of brake pedal travel whether or not the brake pads are worn. It is therefore essential to remove the wheels and check the thickness of the pads at the intervals specified in the service programme.

The brake pads should be changed if the thickness of the friction material is less than 4 mm (0.16 in).

To remove

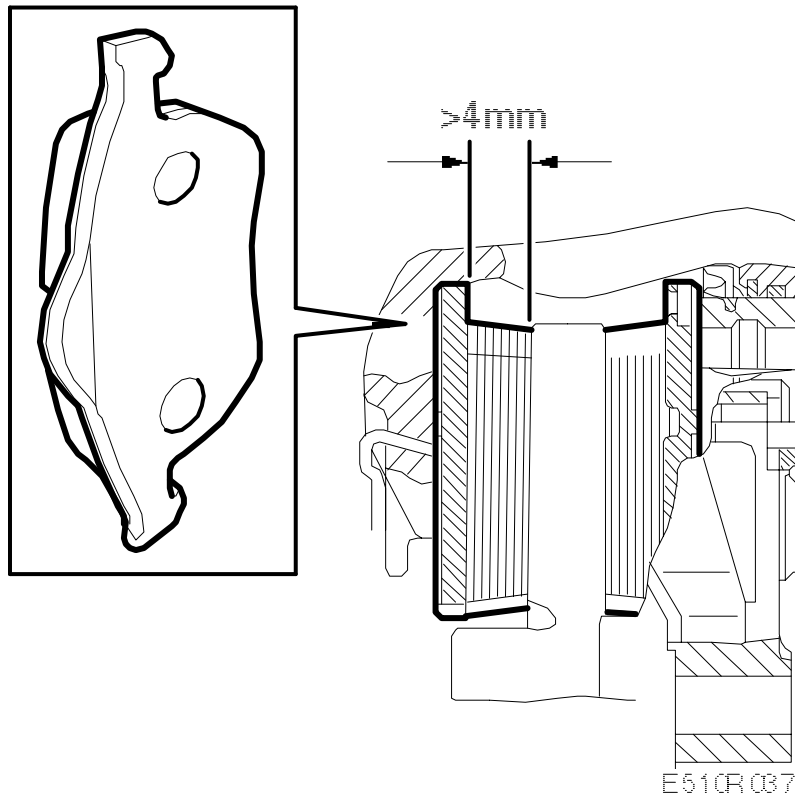
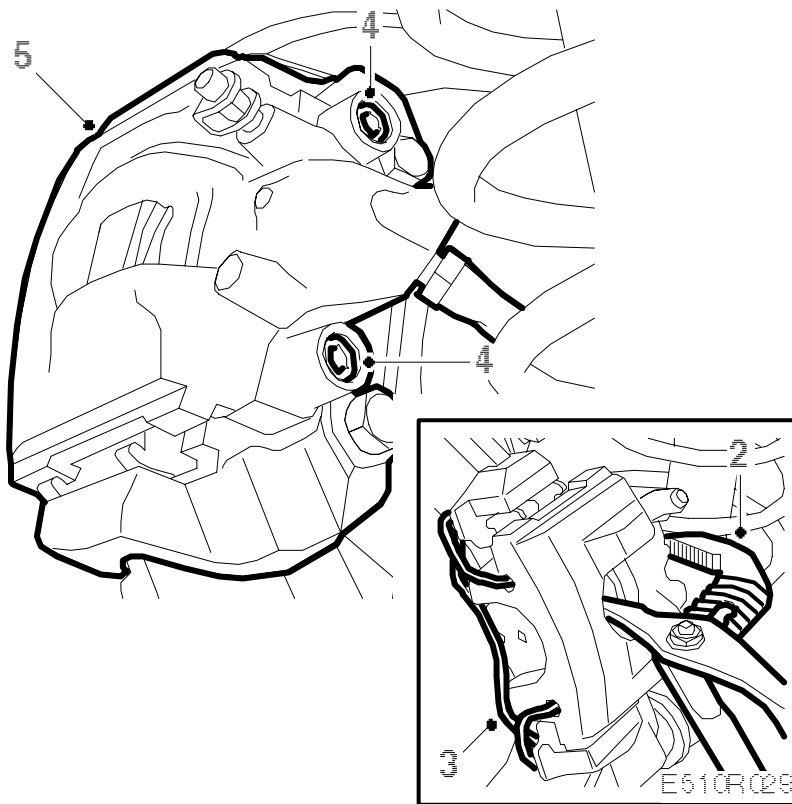

1. Raise the car and remove the wheel.
2. Press back the piston with a pair of slip-joint pliers.
3. Remove the clip from the brake caliper.
4. Remove the dust caps from the guide pins and then remove the guide pins.
- 5.

Lift the brake caliper off the brake disc and suspend it from the suspension strut.

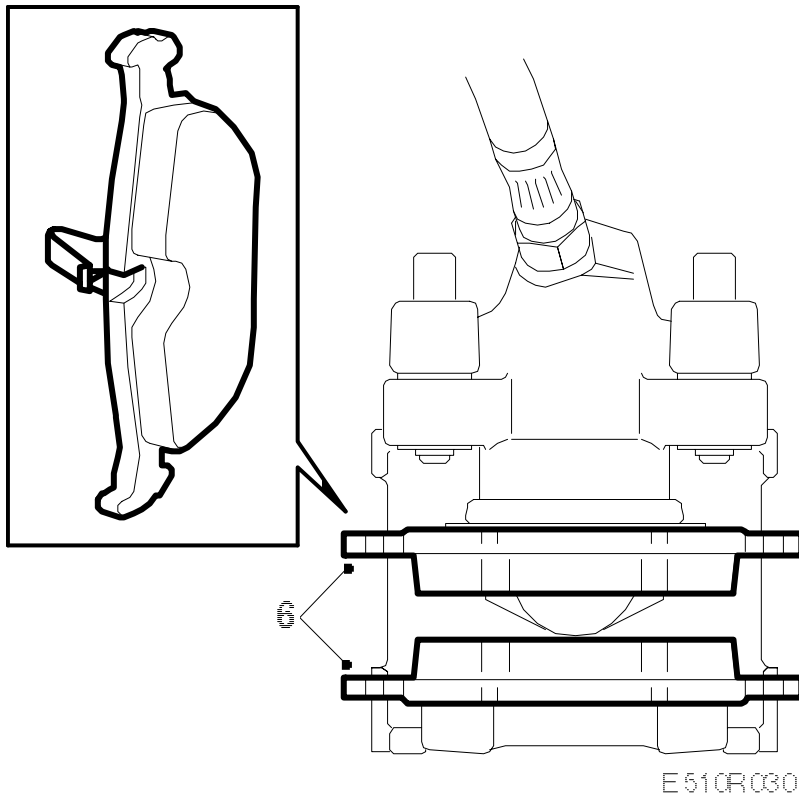

6. Remove the brake pads.

Clean the inside of the brake caliper with a soft wire brush and inspect the dust caps.

To fit

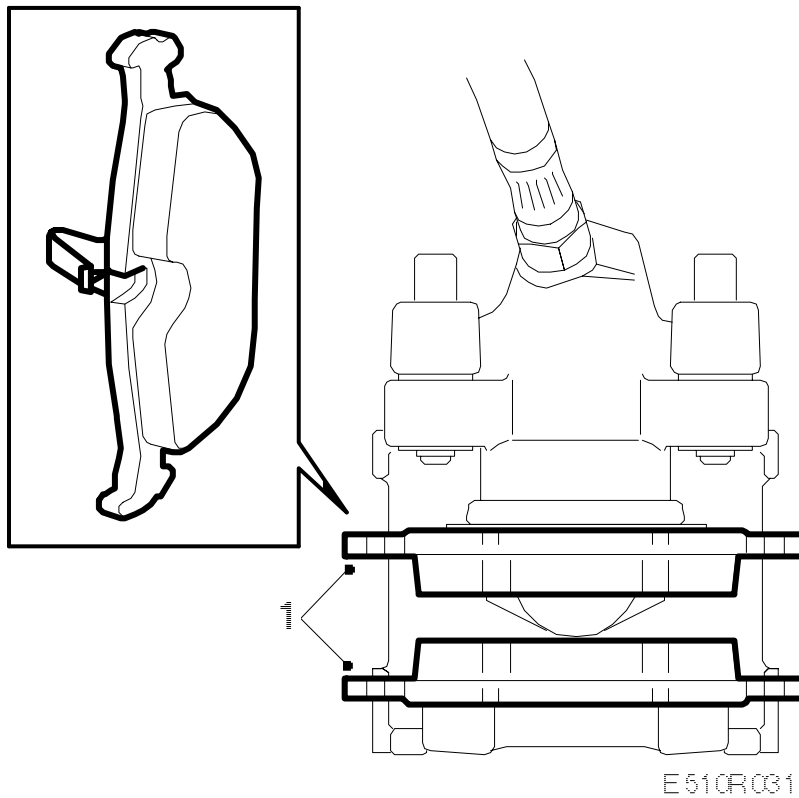

1. Fit the new brake pads into the hydraulic body.

Important

The inner and outer pads are different. The spring-fitted pad must be fitted against the piston.

2. Fit the hydraulic body, clean the guide pins and tighten to torque.

Tightening torque 28 Nm (20 lbf ft).

3. Fit the dust caps and clip, as shown.
4. Fit the wheels, see [Wheels](#).

Tightening torque 110 Nm (81 lbf ft).

Important

The wheel must hang freely when the wheel bolts are being tightened.

5. Lower the car to the floor and depress the brake pedal to force out the brake pistons.

6. Check the level of the brake fluid.